

Robert Bosch GmbH
Power Tools Division
70745 Leinfelden-Echterdingen
Germany

www.bosch-pt.com

1 609 929 R74 (2008.12) O / 107 WEU

GW I 10,8 V-LI Professional



de Originalbetriebsanleitung	el Πρωτότυπο οδηγιών χρήσης
en Original instructions	tr Orijinal işletme talimatı
fr Notice originale	
es Manual original	
pt Manual original	
it Istruzioni originali	
nl Oorspronkelijke gebruiksaanwijzing	
da Original brugsanvisning	
sv Bruksanvisning i original	
no Original driftsinstruks	
fi Alkuperäiset ohjeet	





10,8 V
2 607 336 014

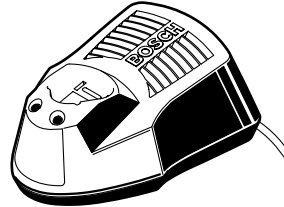

AL 1130 CV
(10,8 V)
2 607 225 134 (EU)
2 607 225 136 (UK)
2 607 225 138 (AU)

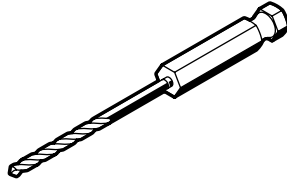

Ø 2 mm	2 608 595 511
Ø 3 mm	2 608 595 512
Ø 4 mm	2 608 595 513
Ø 5 mm	2 608 595 514
Ø 6 mm	2 608 595 515
Ø 8 mm	2 608 595 516



Ø 2, 3, 4, 5, 6 mm	2 608 595 517
--------------------	---------------



Ø 2 mm	2 608 595 518
Ø 3 mm	2 608 595 519
Ø 4 mm	2 608 595 520
Ø 5 mm	2 608 595 521
Ø 6 mm	2 608 595 522
Ø 8 mm	2 608 595 523
Ø 10 mm	2 608 595 524



Ø 2, 3, 4, 5, 6 mm	2 608 595 525
--------------------	---------------



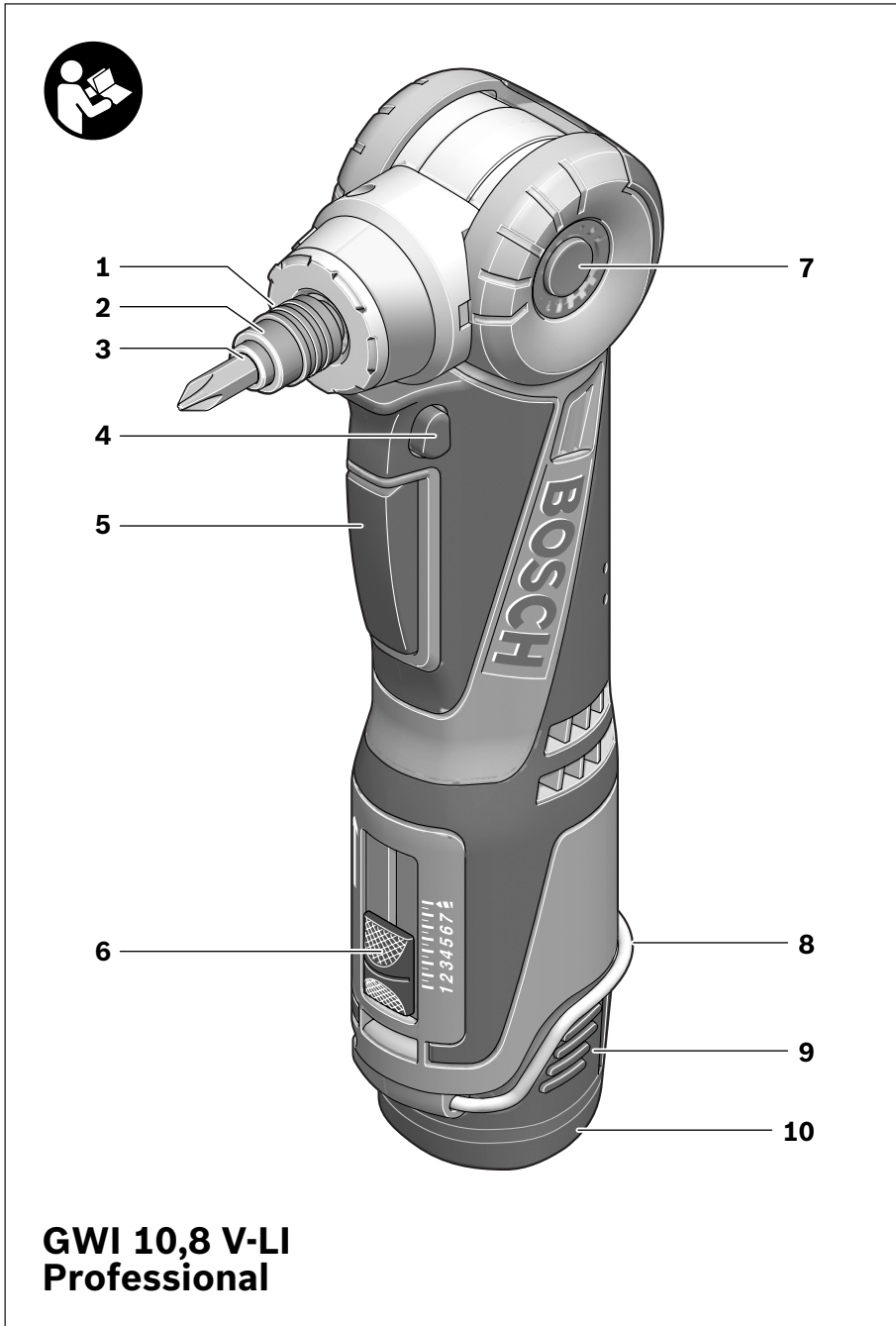

**GW I 10,8 V-LI
Professional**

5 |

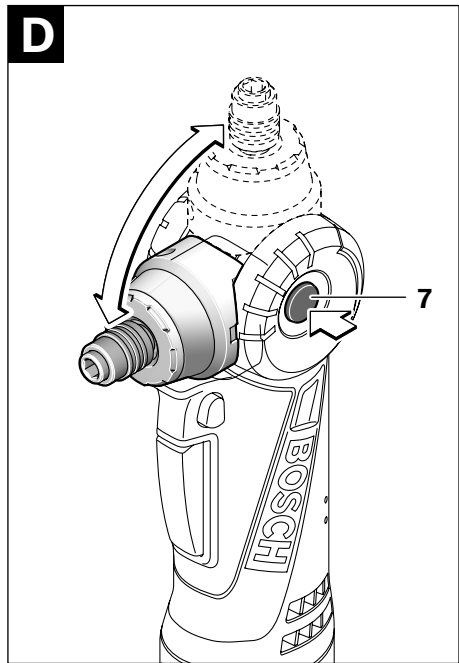
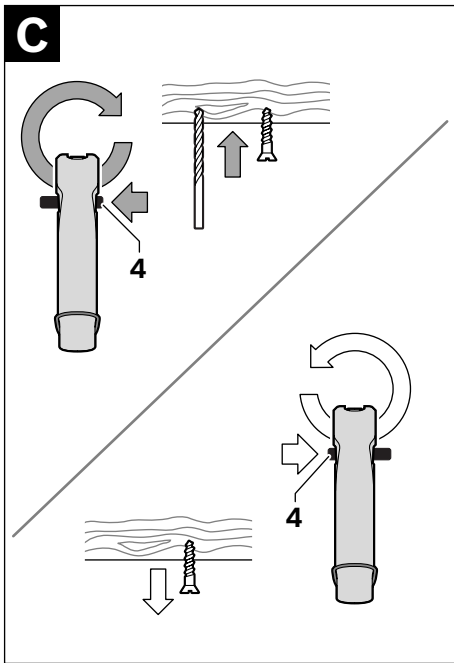
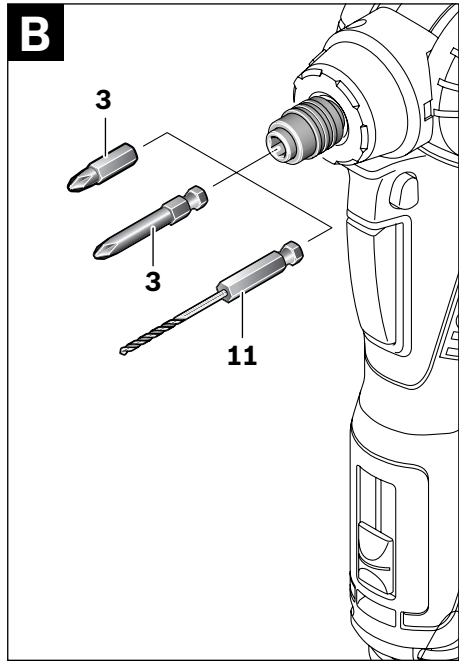
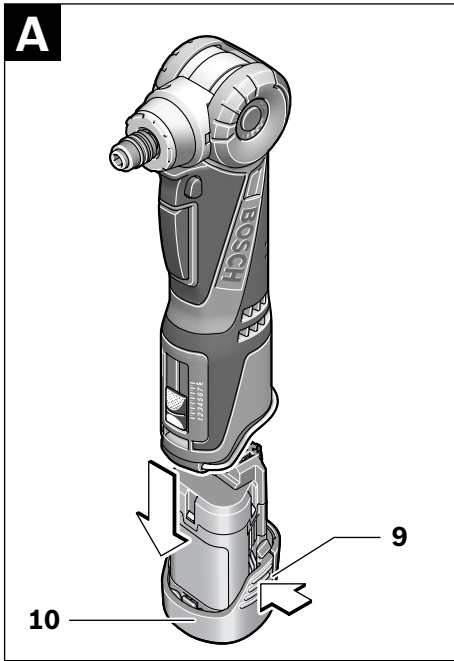

Safety Notes

General Power Tool Safety Warnings

⚠ WARNING Read all safety warnings and all instructions. Failure to follow the warnings and instructions may result in electric shock, fire and/or serious injury.

Save all warnings and instructions for future reference.

The term “power tool” in the warnings refers to your mains-operated (corded) power tool or battery-operated (cordless) power tool.

1) Work area safety

- a) **Keep work area clean and well lit.** Cluttered or dark areas invite accidents.
- b) **Do not operate power tools in explosive atmospheres, such as in the presence of flammable liquids, gases or dust.** Power tools create sparks which may ignite the dust or fumes.
- c) **Keep children and bystanders away while operating a power tool.** Distractions can cause you to lose control.

2) Electrical safety

- a) **Power tool plugs must match the outlet. Never modify the plug in any way. Do not use any adapter plugs with earthed (grounded) power tools.** Unmodified plugs and matching outlets will reduce risk of electric shock.
- b) **Avoid body contact with earthed or grounded surfaces, such as pipes, radiators, ranges and refrigerators.** There is an increased risk of electric shock if your body is earthed or grounded.
- c) **Do not expose power tools to rain or wet conditions.** Water entering a power tool will increase the risk of electric shock.
- d) **Do not abuse the cord. Never use the cord for carrying, pulling or unplugging the power tool. Keep cord away from heat, oil, sharp edges and moving parts.** Damaged or entangled cords increase the risk of electric shock.

e) **When operating a power tool outdoors, use an extension cord suitable for outdoor use.** Use of a cord suitable for outdoor use reduces the risk of electric shock.

f) **If operating a power tool in a damp location is unavoidable, use a residual current device (RCD) protected supply.** Use of an RCD reduces the risk of electric shock.

3) Personal safety

- a) **Stay alert, watch what you are doing and use common sense when operating a power tool. Do not use a power tool while you are tired or under the influence of drugs, alcohol or medication.** A moment of inattention while operating power tools may result in serious personal injury.
- b) **Use personal protective equipment. Always wear eye protection.** Protective equipment such as dust mask, non-skid safety shoes, hard hat, or hearing protection used for appropriate conditions will reduce personal injuries.
- c) **Prevent unintentional starting. Ensure the switch is in the off-position before connecting to power source and/or battery pack, picking up or carrying the tool.** Carrying power tools with your finger on the switch or energising power tools that have the switch on invites accidents.
- d) **Remove any adjusting key or wrench before turning the power tool on.** A wrench or a key left attached to a rotating part of the power tool may result in personal injury.
- e) **Do not overreach. Keep proper footing and balance at all times.** This enables better control of the power tool in unexpected situations.
- f) **Dress properly. Do not wear loose clothing or jewellery. Keep your hair, clothing and gloves away from moving parts.** Loose clothes, jewellery or long hair can be caught in moving parts.

g) If devices are provided for the connection of dust extraction and collection facilities, ensure these are connected and properly used. Use of dust collection can reduce dust-related hazards.

4) Power tool use and care

a) Do not force the power tool. Use the correct power tool for your application. The correct power tool will do the job better and safer at the rate for which it was designed.

b) Do not use the power tool if the switch does not turn it on and off. Any power tool that cannot be controlled with the switch is dangerous and must be repaired.

c) Disconnect the plug from the power source and/or the battery pack from the power tool before making any adjustments, changing accessories, or storing power tools. Such preventive safety measures reduce the risk of starting the power tool accidentally.

d) Store idle power tools out of the reach of children and do not allow persons unfamiliar with the power tool or these instructions to operate the power tool. Power tools are dangerous in the hands of untrained users.

e) Maintain power tools. Check for misalignment or binding of moving parts, breakage of parts and any other condition that may affect the power tool's operation. If damaged, have the power tool repaired before use. Many accidents are caused by poorly maintained power tools.

f) Keep cutting tools sharp and clean. Properly maintained cutting tools with sharp cutting edges are less likely to bind and are easier to control.

g) Use the power tool, accessories and tool bits etc. in accordance with these instructions, taking into account the working conditions and the work to be performed. Use of the power tool for operations different from those intended could result in a hazardous situation.

5) Battery tool use and care

a) Recharge only with the charger specified by the manufacturer. A charger that is suitable for one type of battery pack may create a risk of fire when used with another battery pack.

b) Use power tools only with specifically designated battery packs. Use of any other battery packs may create a risk of injury and fire.

c) When battery pack is not in use, keep it away from other metal objects, like paper clips, coins, keys, nails, screws or other small metal objects, that can make a connection from one terminal to another. Shorting the battery terminals together may cause burns or a fire.

d) Under abusive conditions, liquid may be ejected from the battery; avoid contact. If contact accidentally occurs, flush with water. If liquid contacts eyes, additionally seek medical help. Liquid ejected from the battery may cause irritation or burns.

6) Service

a) Have your power tool serviced by a qualified repair person using only identical replacement parts. This will ensure that the safety of the power tool is maintained.

Safety Warnings for Drills and Screwdriver

- ▶ **Hold power tool by insulated gripping surfaces, when performing an operation where the cutting accessory or fastener may contact hidden wiring.** Cutting accessory and fasteners contacting a "live" wire may make exposed metal parts of the power tool "live" and could give the operator an electric shock.
- ▶ **Use appropriate detectors to determine if utility lines are hidden in the work area or call the local utility company for assistance.** Contact with electric lines can lead to fire and electric shock. Damaging a gas line can lead to explosion. Penetrating a water line causes property damage or may cause an electric shock.

- ▶ **Switch off the power tool immediately when the tool insert jams. Be prepared for high reaction torque that can cause kick-back.** The tool insert jams when:

- the power tool is subject to overload or
- it becomes wedged in the workpiece.

- ▶ **Hold the machine with a firm grip.** High reaction torque can briefly occur while driving in and loosening screws.

- ▶ **Secure the workpiece.** A workpiece clamped with clamping devices or in a vice is held more secure than by hand.

- ▶ **Keep your workplace clean.** Blends of materials are particularly dangerous. Dust from light alloys can burn or explode.

- ▶ **Always wait until the machine has come to a complete stop before placing it down.** The tool insert can jam and lead to loss of control over the power tool.

- ▶ **Do not open the battery.** Danger of short-circuiting.



Protect the battery against heat, e. g., also against continuous sun irradiation and fire. There is danger of explosion.

- ▶ **In case of damage and improper use of the battery, vapours may be emitted. Provide for fresh air and seek medical help in case of complaints.** The vapours can irritate the respiratory system.

- ▶ **When the battery is defective, liquid can escape and come into contact with adjacent components. Check any parts concerned.** Clean such parts or replace them, if required.

- ▶ **Use the battery only in conjunction with your Bosch power tool.** This measure alone protects the battery against dangerous overload.

Functional Description



Read all safety warnings and all instructions. Failure to follow the warnings and instructions may result in electric shock, fire and/or serious injury.

While reading the operating instructions, unfold the graphics page for the machine and leave it open.

Intended Use

The machine is intended for driving in and loosening screws as well as for drilling in wood, metal, ceramic and plastic, especially at hard to reach locations.

Product Features

The numbering of the product features refers to the illustration of the machine on the graphics page.

- 1 Locking sleeve
- 2 Tool holder
- 3 Screwdriver bit*
- 4 Rotational direction switch
- 5 On/Off switch
- 6 Torque selector switch
- 7 Release button for angle selection of drill head
- 8 Utility clip
- 9 Battery unlocking button
- 10 Battery
- 11 Drill bit with hexagon shank*

***Accessories shown or described are not part of the standard delivery scope of the product. A complete overview of accessories can be found in our accessories program.**

Technical Data

Cordless angle drill/driver	GWI 10,8 V-LI Professional	
Article number		3 601 C6J 9..
Rated voltage	V=	10.8
No-load speed	min ⁻¹	0 – 585
Max. torque for hard/soft screwdriving application according to ISO 5393	Nm	13/5
Torque adjustment range	Nm	2.6 – 5.2
Max. screw dia.	mm	5
Max. drilling dia.		
– Steel	mm	8
– Wood	mm	10
Weight according to EPTA-Procedure 01/2003	kg	1.1
Please observe the article number on the type plate of your machine. The trade names of the individual machines may vary.		

Noise/Vibration Information

Measured values determined according to EN 60745.

Typically the A-weighted sound pressure level of the product is less than 70 dB(A). Uncertainty K = 3 dB.

The noise level when working can exceed 80 dB(A).

Wear hearing protection!

Vibration total values (triax vector sum) determined according to EN 60745:

Drilling into metal: Vibration emission value

$a_h = 2.5 \text{ m/s}^2$, Uncertainty $K = 1.5 \text{ m/s}^2$,

Screwdriving: Vibration emission value

$a_h = 2.5 \text{ m/s}^2$, Uncertainty $K = 1.5 \text{ m/s}^2$.

The vibration emission level given in this information sheet has been measured in accordance with a standardised test given in EN 60745 and may be used to compare one tool with another. It may be used for a preliminary assessment of exposure.

The declared vibration emission level represents the main applications of the tool. However if the tool is used for different applications, with different accessories or poorly maintained, the vibration emission may differ. This may significantly increase the exposure level over the total working period.

An estimation of the level of exposure to vibration should also take into account the times when the tool is switched off or when it is running but not actually doing the job. This may significantly reduce the exposure level over the total working period.

Identify additional safety measures to protect the operator from the effects of vibration such as: maintain the tool and the accessories, keep the hands warm, organisation of work patterns.

Declaration of Conformity

We declare under our sole responsibility that the product described under "Technical Data" is in conformity with the following standards or standardization documents: EN 60745 according to the provisions of the directives 2004/108/EC, 98/37/EC (until 28 Dec 2009), 2006/42/EC (from 29 Dec 2009).

Technical file at:

Robert Bosch GmbH, PT/ESC,
D-70745 Leinfelden-Echterdingen

Dr. Egbert Schneider
Senior Vice President
Engineering

Dr. Eckerhard Strötgen
Head of Product
Certification

ppa. Schneider *i.v. Strötgen*

Robert Bosch GmbH, Power Tools Division
D-70745 Leinfelden-Echterdingen
21.11.2008

Assembly

Battery Charging (see figure A)

- **Use only the battery chargers listed on the accessories page.** Only these battery chargers are matched to the lithium ion battery of your power tool.

Note: The battery is supplied partially charged. To ensure full capacity of the battery, completely charge the battery in the battery charger before using your power tool for the first time.

The lithium ion battery can be charged at any time without reducing its service life. Interrupting the charging procedure does not damage the battery.

The Li-ion battery is protected against deep discharging by the "Electronic Cell Protection (ECP)". When the battery is empty, the machine is switched off by means of a protective circuit: The inserted tool no longer rotates.

⚠ WARNING Do not continue to press the On/Off switch after the machine has been automatically switched off. The battery can be damaged.

To remove the battery **10** press the unlocking buttons **9** and pull out the battery downwards. Do not exert any force.

The battery is equipped with a NTC temperature control which allows charging only within a temperature range of between 0 °C and 45 °C. A long battery service life is achieved in this manner.

Observe the notes for disposal.

Changing the Tool (see figure B)

- ▶ Before any work on the power tool, remove the battery.

Inserting

Pull the locking sleeve **1** toward the front and then push the insert tool to the stop into the tool holder **2**. The insert tool is automatically locked.

Removing

Pull the locking sleeve **1** forward and remove the insert tool.

Dust/Chip Extraction

- ▶ Dusts from materials such as lead-containing coatings, some wood types, minerals and metal can be harmful to one's health. Touching or breathing-in the dusts can cause allergic reactions and/or lead to respiratory infections of the user or bystanders.

Certain dusts, such as oak or beech dust, are considered as carcinogenic, especially in connection with wood-treatment additives (chromate, wood preservative). Materials containing asbestos may only be worked by specialists.

- Provide for good ventilation of the working place.
- It is recommended to wear a P2 filter-class respirator.

Observe the relevant regulations in your country for the materials to be worked.

Operation

Starting Operation

Inserting the Battery

- ▶ Use only original Bosch lithium ion batteries with the voltage listed on the nameplate of your power tool. Using other batteries can lead to injuries and pose a fire hazard.

Note: Use of batteries not suitable for the machine can lead to malfunctions of or cause damage to the power tool.

Reversing the Rotational Direction (see figure C)

The rotational direction switch **4** is used to reverse the rotational direction of the machine. However, this is not possible with the On/Off switch **5** actuated.

Right Rotation: For drilling and driving in screws, push the rotational direction switch **4** left to the stop.

Left Rotation: For loosening or unscrewing screws, push the rotational direction switch **4** right to the stop.

Setting the Torque

With the torque selector switch **6**, you can preselect the required torque in 8 steps. When the torque setting is adjusted correctly, the insert tool is stopped as soon as the screw is driven flush into the material or when the set torque is reached. In the “” position, the safety clutch is deactivated; e.g., for drilling. In left rotation the safety clutch is deactivated.

Switching On and Off

To **start** the machine, press the On/Off switch **5** and keep it pressed.

To switch off the machine, **release** the On/Off switch **5**.

Adjusting the Speed

The speed of the switched on power tool can be variably adjusted, depending on how far the On/Off switch **5** is pressed.

Light pressure on the On/Off switch **5** results in a low rotational speed. Further pressure on the switch results in an increase in speed.

Fully automatic spindle locking (Auto-lock)

When the On/Off switch **5** is not pressed, the drill spindle and thus the tool holder are locked. This enables screws to be screwed in, even when the battery is empty and allows for the machine to be used as a screwdriver.

Temperature Dependent Overload Protection

When using as intended for, the power tool cannot be subject to overload. When the load is too high or the allowable battery temperature of 70 °C is exceeded, the electronic control switches off the power tool until the temperature is in the optimum temperature range again.

Protection Against Deep Discharging

The Li-ion battery is protected against deep discharging by the “Electronic Cell Protection (ECP)”. When the battery is empty, the machine is switched off by means of a protective circuit: The inserted tool no longer rotates.

Angle Selection of Drill Head (see figure D)

The drill head can be locked in 5 different angle positions. Push the release button **7** and swivel the tool head to the required position. Then, let go of the release button **7** again.

- ▶ **Before starting operation, check if the drill head is locked in the respective angle position.** Danger of injury.

Working Advice

- ▶ **Apply the power tool to the screw only when it is switched off.** Rotating tool inserts can slip off.

Utility Clip

The swivelling utility clip **8** can be used to hang the power tool onto a hook. In this manner, both hands are free and the power tool is ready to hand.

Maintenance and Service

Maintenance and Cleaning

- ▶ **Before any work on the power tool, remove the battery.**
- ▶ **For safe and proper working, always keep the machine and ventilation slots clean.**

When the battery is no longer operative, please refer to an authorised after-sales service agent for Bosch power tools.

If the machine should fail despite the care taken in manufacturing and testing procedures, repair should be carried out by an after-sales service centre for Bosch power tools.

In all correspondence and spare parts order, please always include the 10-digit article number given on the type plate of the machine.

After-sales Service and Customer Assistance

Our after-sales service responds to your questions concerning maintenance and repair of your product as well as spare parts. Exploded views and information on spare parts can also be found under:

www.bosch-pt.com

Our customer consultants answer your questions concerning best buy, application and adjustment of products and accessories.

Great Britain

Robert Bosch Ltd. (B.S.C.)
P.O. Box 98
Broadwater Park
North Orbital Road
Denham
Uxbridge
UB 9 5HJ
Tel. Service: +44 (0844) 736 0109
Fax: +44 (0844) 736 0146
E-Mail: SPT-Technical.de@de.bosch.com

Ireland

Origo Ltd.
Unit 23 Magna Drive
Magna Business Park
City West
Dublin 24
Tel. Service: +353 (01) 4 66 67 00
Fax: +353 (01) 4 66 68 88

Australia, New Zealand and Pacific Islands

Robert Bosch Australia Pty. Ltd.
Power Tools
Locked Bag 66
Clayton South VIC 3169
Customer Contact Center
Inside Australia:
Phone: +61 (01300) 307 044
Fax: +61 (01300) 307 045
Inside New Zealand:
Phone: +64 (0800) 543 353
Fax: +64 (0800) 428 570
Outside AU and NZ:
Phone: +61 (03) 9541 5555
www.bosch.com.au

Transport

The battery is tested according to UN document ST/SG/AC.10/11/Rev.3 Part III, subsection 38.3. It has effective protection against internal overpressure and short circuiting as well as devices for the prevention of violent rupture and dangerous reverse current flow.

The lithium-equivalent content in the battery is below applicable limit values. Therefore, the battery is not subject to national or international regulations pertaining to dangerous mediums, neither as an individual component nor when inserted into a machine. However, the regulations governing dangerous goods may be relevant when transporting several batteries. In this case, it can be necessary to comply with special conditions (e.g., concerning the packaging). For more information, please refer to the instruction sheet (in English) under the following Internet address:

<http://purchasing.bosch.com/en/start/Allgemeines/Download/index.htm>

Disposal

The machine, accessories and packaging should be sorted for environmental-friendly recycling.

Only for EC countries:



Do not dispose of power tools into household waste!

According to the European Guideline 2002/96/EC for Waste Electrical and Electronic Equipment and its implementation into national law, power tools that are no longer usable must be collected separately and disposed of in an environmentally correct manner.

Battery packs/batteries:



Li-ion:

Please observe the instructions in section "Transport", page 20.



Do not dispose of battery packs/batteries into household waste, fire or water. Battery packs/batteries should be collected, recycled or disposed of in an environmental-friendly manner.

Only for EC countries:

Defective or dead out battery packs/batteries must be recycled according the guideline 91/157/EEC.

Batteries no longer suitable for use can be directly returned at:

Great Britain

Robert Bosch Ltd. (B.S.C.)
P.O. Box 98
Broadwater Park
North Orbital Road
Denham
Uxbridge
UB 9 5HJ
Tel. Service: +44 (0844) 736 0109
Fax: +44 (0844) 736 0146
E-Mail: SPT-Technical.de@de.bosch.com

Subject to change without notice.

