



捷宝闪光灯

SPEEDLITE



中文
English

F版使用说明书
Instruction Manual

Thank you for this purchasing this speedlite.

Please read carefully this manual before using, and then use this speedlite correctly on the base of though understanding.

Safety instruction

1. Never trigger the speedlite around flammable gas or liquid gas in the vicinity (such as gasoline and solvents) ! There be risk of explosion!

2. Neither shoot with the speedlite at drivers who are driving cars, buses or trains, nor the rider of motor and bicycle. They may be temporarily blind of the bright light and cause traffic accident.

3. Never trigger the speedlite at close range at the eyes! Using the speedlite directly at people or animal's eyes will damage the retinas and cause serious visual disturbance, even blindness.

4. Only use the batteries listed in this manual!

5. Never place the batteries in high-temperature environment, such as under the sun or in the fire.

6. Should remove the drained battery from the speedlite. Because the alkaline liquid exuding from the battery will damage the speedlite.

7. Do not charge the dry battery.

8. Note to protect the speedlite under extremely hot or damp environment!

9. Never put the speedlite in the glove box of the car dashboard. When trigger the speedlite, never put any light-proof items before or on the reflection shield. There can not be any dirt on the reflection, or the high energy that the speedlite emitted will burn the item or damage the reflection shield.

10. Never touch the speedlite after continuous triggering. There will be danger of burning!

11. Never unpack the speedlite by yourself! There will be danger of electricity shock! Non professional personal can not fix the component in the speedlite.

12. When doing fast continuous shooting under optical output, must stop 15 minutes every 10 continuous flashes.

13. When under optical output, continuously using the speedlite by high-speed recycling and the zoom position is less than 36mm, the diffuser will give heat out of the high energy.

14. The quick change of temperature will cause vapor condensation.

15. Never use any defected battery to this speedlite.

The Speedlite Features

1. TTL flash

2. Manual flash

3. Multi flash

4. Wireless slave unit function: Compatibility with the Canon and Nikon wireless flash system, realize TTL from machine, manual and frequency flash

5. S1.S2 Light flashing mode

6. Flash control by Camera (Only for the newest Canon Version)

7. Rear-curtain Sync

8. Voice prompt

9. Custom function

10. Power save mode

11. Overheating protection

12. Automatic save function

13. Large size LCD display

14. Manual, Auto zoom function

15. Quick response: Full output recycle time only 2.9 seconds

16. Support high speed continuous shooting: In 1/16 brightness and blew. It can support 12EPS high speed continuous shooting.

Nomenclature

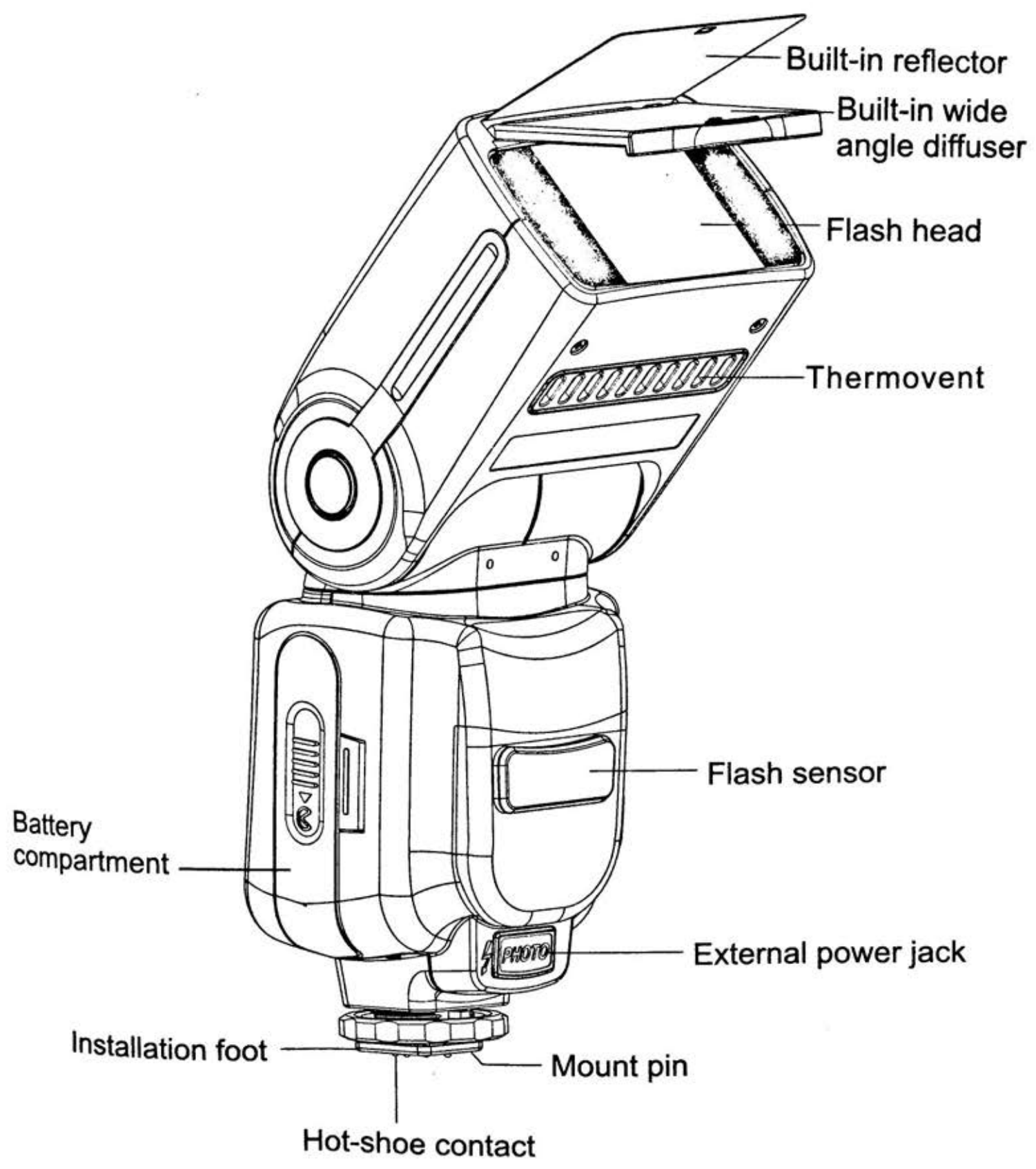

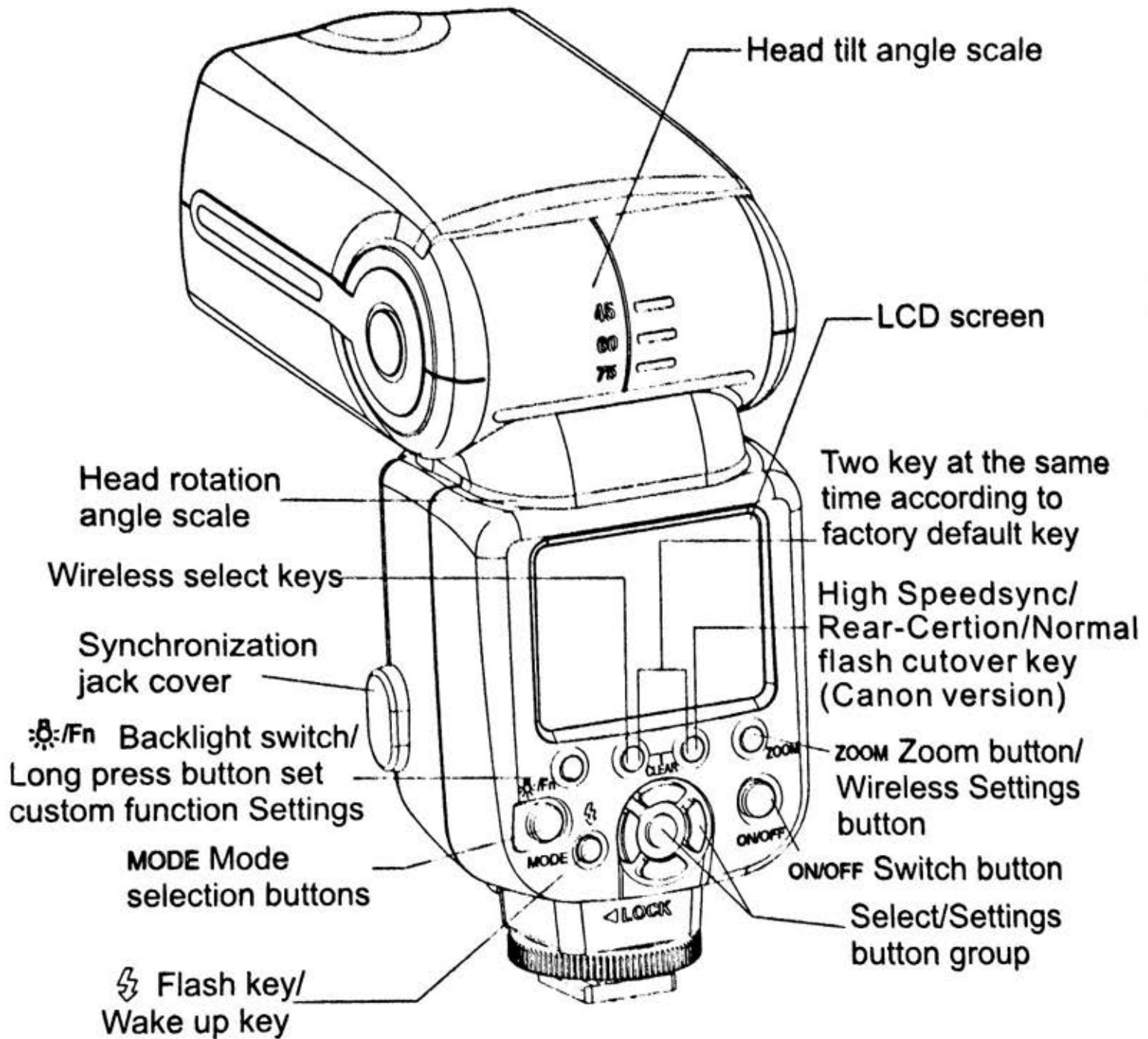

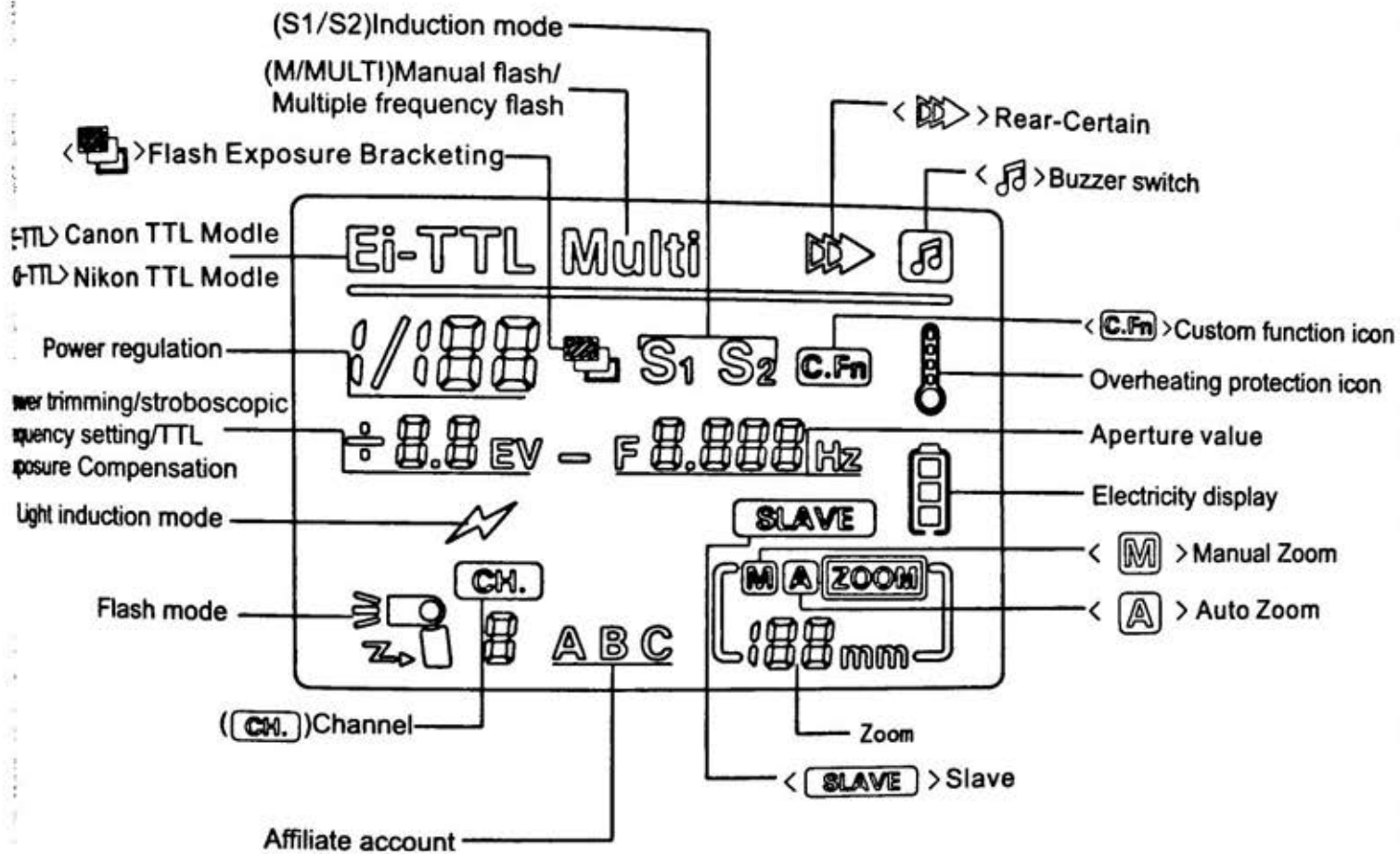

AF-Assist illuminator

When working under a darkness condition, the automatic AF which is in the right ahead of the flash light may temporary project red hard light to assist focusing.

It may disturb the subject, you can turn to manual focusing.

Set the Bounce Drection

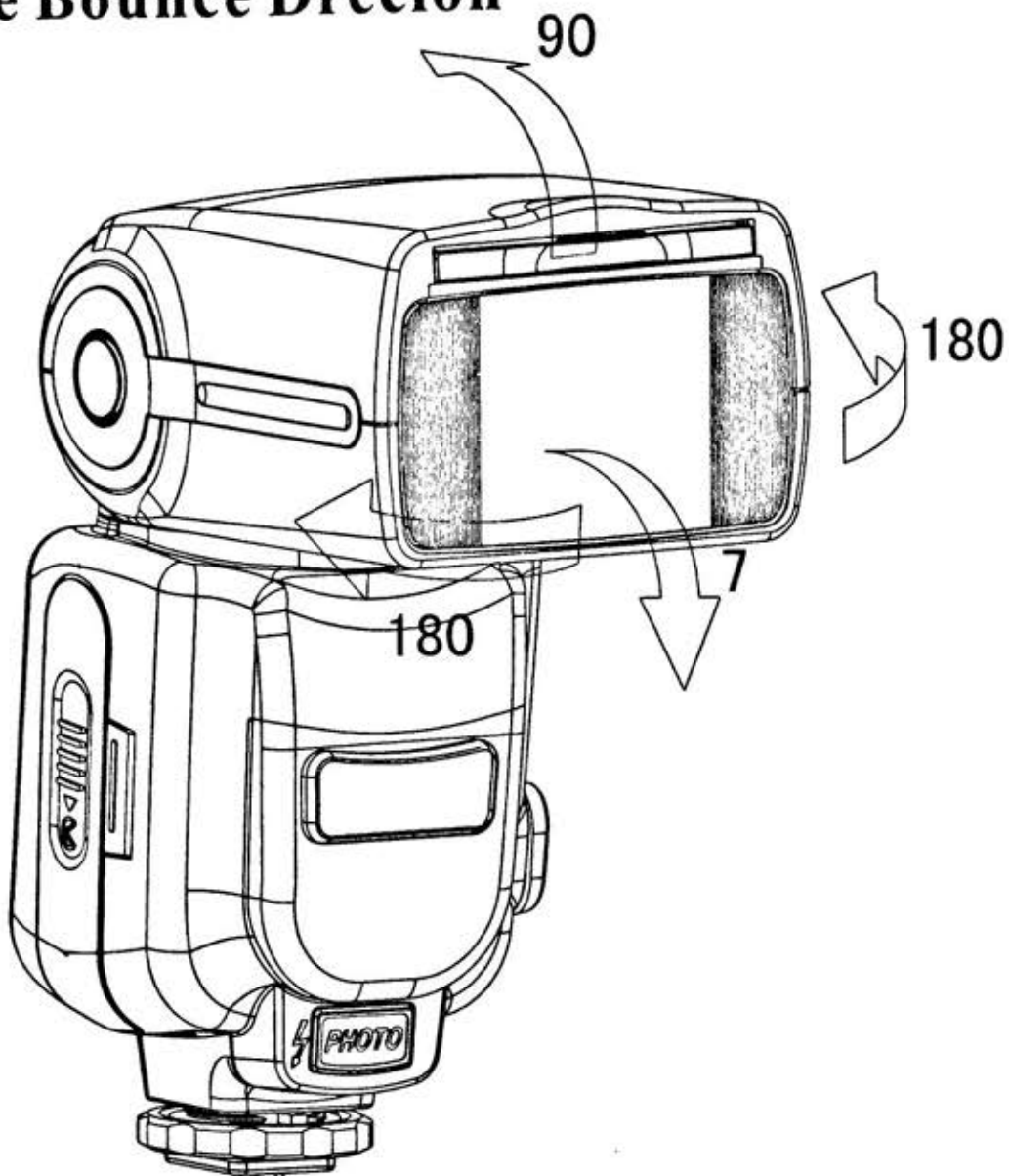

This speedlite can rotate up to 90 degree and down to 7 degree. Horizontal rotating 'left to right' or 'right to left' 180 degree. Rotating the speedlite to the ceiling or wall to make the image more natural.

Basic Operating

Installing the batteries

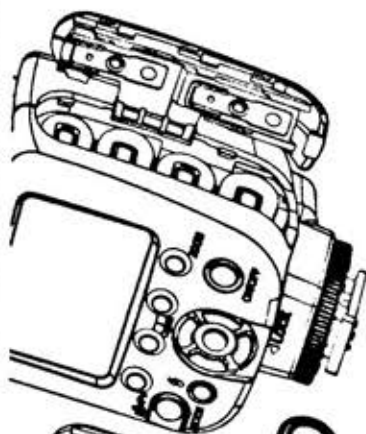

1. Open the cover
According to the direction of arrow to slid the battery cover then open it.

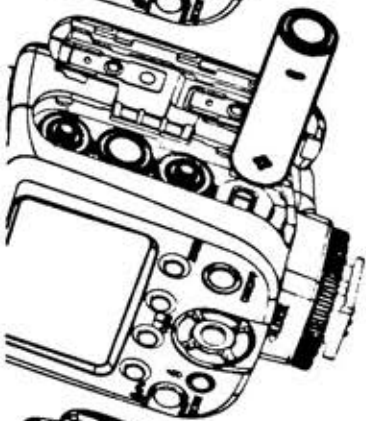

2. Install the batteries
According to the battery icon in the bulkhead [+]
and [-] signs into the battery, make sure the
battery positive and negative contacts are
correctly oriented.

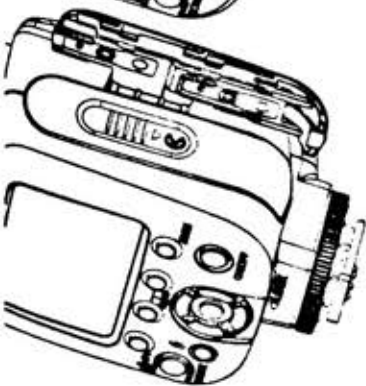

3. Close the cover
Sliding direction of the arrow battery cover, turn
it off

The applicative battery or chargeable battery

Every battery below is applicative to this speedlite.

A. 4 (AA) alkaline manganese battery (1.5V). The battery can meet medium power demand and does not need maintenance, but it can not be recharged.

B. 4 (AA) nickel-cadmium battery (1.2V). The battery recycles quickly and can be recharged, so it is economic.

C. 4 (AA) nickel-metal hydride batteries (1.2V). This battery's power obviously exceed that of nickel-cadmium battery, and it is less

harmful to the environment (do not contain cadmium).

D. 4 (AA) lithium battery (1.5V). This battery has large capacity and is low of self-discharge rate and in no need of maintenance.

E. 4 (AA) hydrogen oxygen cell (1.5V). This battery is also called (OXYRIDE), its capacity is larger and its service life is about 1.5 times of alkaline battery's. So it is very applicative in electronic products of high power consumption.

If use external acceleration power box, battery box or power pack, please put 4 (AA) batteries into the speedlite to supply CPU. If don't use the speedlite for a long time, you should remove the batteries.

Attaching to the camera

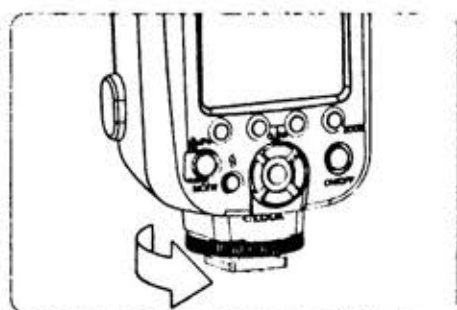

1. Prepare to attach the speedlite
Rotating the locking plate up to the highest point as the marked arrow.

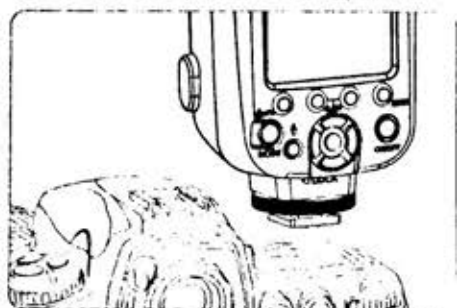

2. Install the speedlite
Installing the speedlite light's mounting support into the hot shoe of camera.

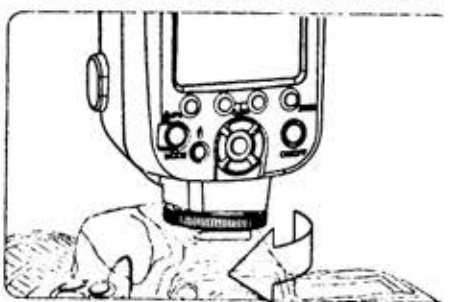

3. Secure the speedlite
Tightening the locking plate as the marked arrow.

4. Detach the speedlite
Rotating the locking plate up to the highest point, then detach the speedlite from the hot shoe.

- Note: Make sure the speedlite and camera are turned off.
- Do not forcibly pull out force.

Turn on the power

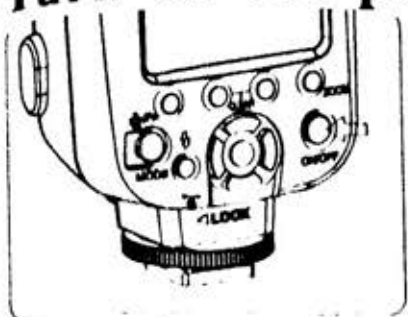

Press the Power button (ON/OFF) for two seconds to turn on/off the speedlite.

In order to save battery power and avoid battery leakage, the default settings are as follows:

After automatically shutting off the power, when the speedlite does not work within 60 seconds, the CPU automatically enters hibernation. In this case, press any key to wake up the speedlite. When the speedlite does not work for more than 30 minutes, the CPU will shut down automatically.

If the speedlite is not used for a long period of time, it is recommended to use the main power switch to turn off the speedlite and remove the power source (battery). Before removing the battery, turn off the power of the speedlite.

After the speedlite capacitor is fully charged, the speedlite PILOT button lights up, indicating that the speedlite is ready to trigger. This means that the next time you can use the speedlite when shooting.

State of charge indicator

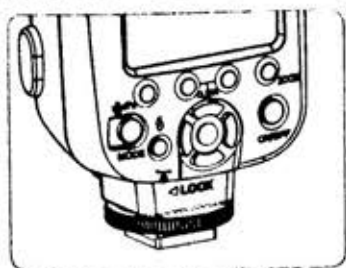

Before shooting, confirm that the flash charging indicator light and camera viewfinder lights have been lit.

Extended Interface

External power supply by extending the interface and completing PC synchronization

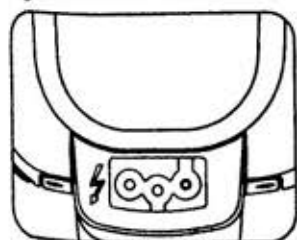

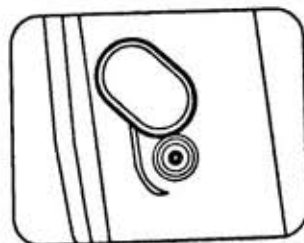

1. The external power connector provides more adequate power.



2. Connect with the PC sync. Make sure the camera and speedlite are synchronized.

TTL Flash

Set the camera's shooting mode to <P>(Program automatic exposure) or <  > (Auto),when fully automatic flash will make photography became as simple as <P> mode and <  > mode under normal automatic exposure.

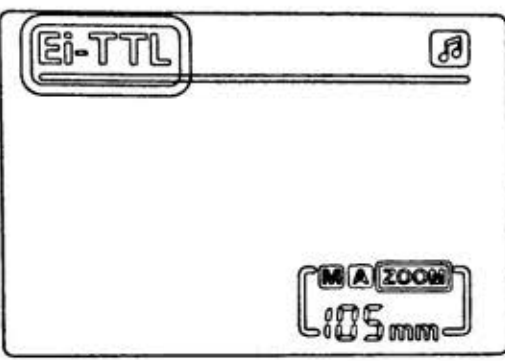
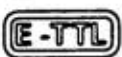
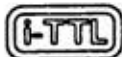
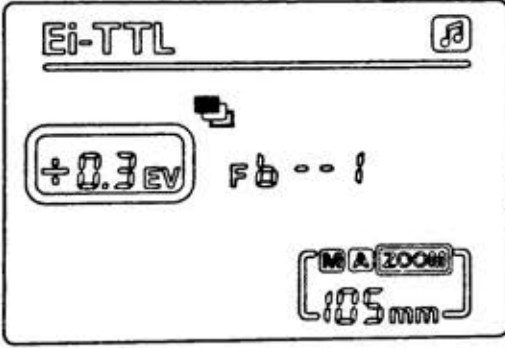
 The LCD display shows 'Ei-TTL' in a rounded rectangle at the top left, a small speaker icon at the top right, and 'M A ZOOM' and 'i25mm' at the bottom.	<p>Set the flash exposure compensation value</p> <ol style="list-style-type: none">1.Select the flash mode2.Press 【MODE】 mode button until the LCD display  Canon  Nikon
 The LCD display shows 'Ei-TTL' at the top left, a speaker icon at the top right, '+0.3EV' in a rounded rectangle in the middle left, 'Fb -- ' in the middle right, and 'M A ZOOM' and 'i25mm' at the bottom.	<p>Set the flash exposure compensation value.</p> <p>When press five select button settings group 【Up】 【Down】 to set the compensation value.</p>

1.Select the Settings button group **【RIGHT】** keys,power values increase sequentially.

Select the Settings button group **【LEFT】** keys,power values decrease sequentially.

2.The compensation value is in the range of +3.0EV to -3.0EV.

The compensation value icon:

0EV→+0.3EV→+0.7EV→+1.0EV→+1.3EV→+1.7EV→. . . →+3.0EV

0EV→-0.3EV→-0.7EV→-1.0EV→-1.3EV→-1.7EV→. . . →-3.0EV

Using E-TTL and Autoflash in the shooting Modes

Just set camera's shooting mode to <AV/A>(aperture -priority AE), <TV/S>(shutter-priority AE), or <M>(manual) and you can use E-TTL/i-TTL autoflash.

TV	<p>Select this mode when you want to set the shutter speed manually. The camera will then automatically set aperture matching the shutter speed to obtain a standard exposure. If the aperture display blinks, it means that the background exposure will be underexposed or overexposed. Adjust the shutter speed until the aperture display stops blinking.</p>
AV	<p>Select this mode when you want to set the aperture manually. The camera will then automatically set the shutter speed matching the aperture to obtain a standard exposure. If the background is dark like a night scene, a slow sync speed will be used to obtain a standard exposure of both the main subject and background. Standard exposure of the main subject is obtained with the flash, while a standard exposure of the background is obtained with a slow shutter speed. Since a slow shutter speed will be used for low-light scenes, using a tripod is recommended. If the shutter speed display blinks, it means that the background exposure will be underexposed or overexposed. Adjust the aperture until the shutter speed display stops blinking.</p>
M	<p>Select this mode if you want to set both the shutter speed and aperture manually. Standard exposure of the main subject is obtained with the flash. The exposure of the background is obtained with the shutter speed and aperture combination you set.</p>

If you use the <DEP> or <A-DEP> shooting mode, the result will be the same as using the <P>(Program AE) mode.

Flash Sync Speeds and Apertures Used

	Shutter Speed Setting	Aperture Setting
P	Set automatically(1/60 sec.~1/Xsec.)	Automatic
TV/S	Set manually(30 sec.~1/Xsec.)	Automatic
AV/A	Set automatically(30 sec.~1/Xsec.)	Manual
M	Set manually(buLb,30 sec.~1/Xsec.)	Manual

1/X sec.is the camera's maximum flash sync speed.

FEB: Set the Flash exposure bracketing value

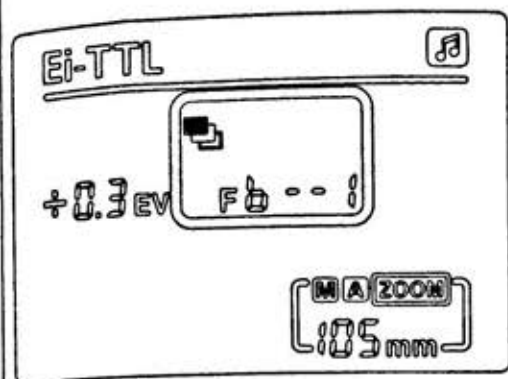

You can take three flash shots while automatically changing the flash output for each shot up to ± 3 stops in 1/3-stop increments (1/2-stops increments if the camera enables only 1/2-stop increments). This is called FEB(Flash Exposure Bracketing). For Feb,set the camera's drive mode to "single shot".Before shooting to ensure that flash ready.

Press "Five select settings button group" **【Up】** **【Down】** key to set the required exposure bracketing value.

1, Press "Five select settings button group" **【Up】** key,bracketing value increases;

Press "Five select settings button group" **【Down】** key,bracketing value decreasing.

2.The FEB is in the range of 0-3.0.

The FEB icon:

0	0.3	0.7	1.0	1.3	1.7	2.0	2.3	2.7	3.0
---	-----	-----	-----	-----	-----	-----	-----	-----	-----

FEL:Flash exposure lock

Flash exposure lock locks the correct flash exposure setting for any part of the scene. With <TTL> displayed on the LCD panel, You press the camera's <FEL>button,If the camera does not have the <FEL>button, press the "*" button. Nikon camera press "FV" button.If the camera support flash exposure lock: connect the flash screen under TTL mode, you can set the flash on the camera exposure by locking, after set, the speedlite will fire a preflash and the required flash output for the subject is retained in memory.The camera will calculate the flash compatible output data,you have time to composition again,after finishing composition can press the shutter to shot (this feature requires you to use the camera itself support,please refer to your camera manual settings).

Manual flash mode M

When you need a manual exposure, according to own requirements to set the brightness of the flash output between 1/128 power to 1/1 full power. Adjust the flash output with 1/3 speed increment, press the zoom button **【ZOOM】** into the manual zoom.

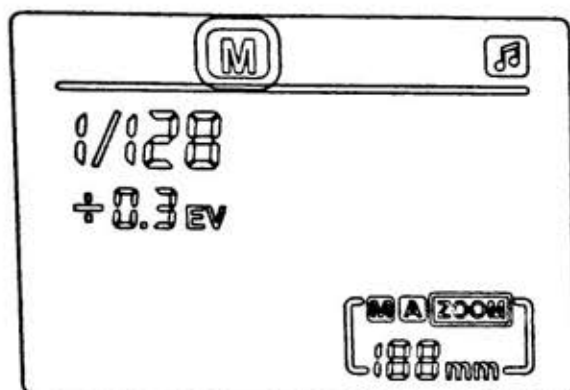

Select the flash mode

Press **【MODE】** mode button until the LCD display **M**.

Power setting

1. Select the Settings button group

【RIGHT】 keys, power values increase sequentially.

Icon: 1/128 → 1/64 → 1/32 → ... → 1/1

2. Select the Settings button group

【LEFT】 keys, power values decrease sequentially.

Icon: 1/1 → 1/2 → 1/4 → ... → 1/128

3. Select the Settings button group

【UP】 【DOWN】 keys, Fine tuning of the value of power of the flash.

Icon:

0EV → +0.3EV → +0.7EV

0EV → -0.3EV → -0.7EV

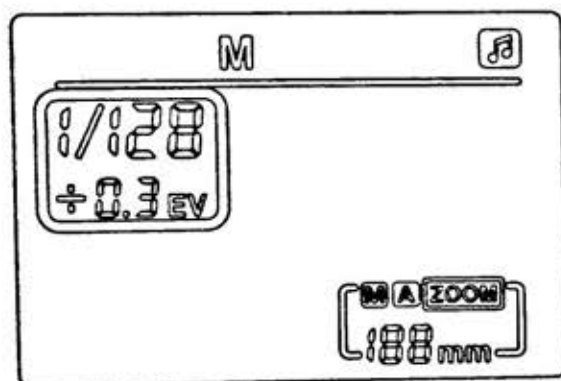

Stroboscopic flash mode(Multi)

Using Multi mode, you can issue a series of quick flash, it can shoot multiple images of moving objects on a photo, you can set the flash frequency (number of flashes per second can use Hz to show), the number of flashes and flash output. During repeated Multi mode, Single exposure create a strobe effect of multiple exposures. This mode is often used when shooting moving objects.

To prevent the flash head overheat and damage, do not perform more than 10 times in a row strobe flash burst. Between twice repeated exposure operation please let flash plenty of time for the callback. After flash work for 10 times please let it cool for at least 15 minutes, if you are trying to perform more than 10 times in a row strobe flash burst the flash may automatically stop to prevent overheating of the flash head. If this happens, please let the flash cool for at least 15 minutes. Please use a new battery or a fully charged battery to operate this mode.

Under Strobe mode (Multi), It support flash power, time of flash as well as frequency regulation.

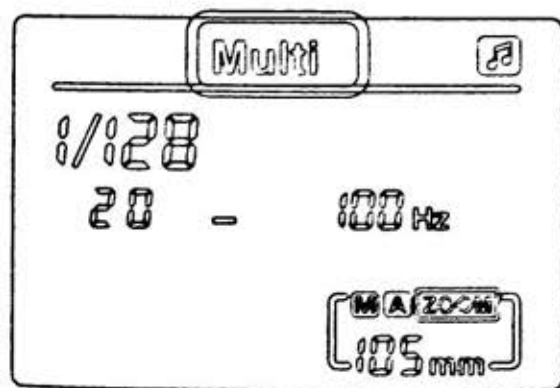

Select the flash mode

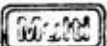
Press **【MODE】** mode button until the LCD display  .

Frequency setting

Select the setting button group **【MIDDLE】** key of settings button group to display  flicker, Press select settings button group **【LEFT】** **【RIGHT】** to set the frequency. The available flash frequency is 1HZ-199HZ. After value setted then select the setting button group **【MIDDLE】** key to confirm.

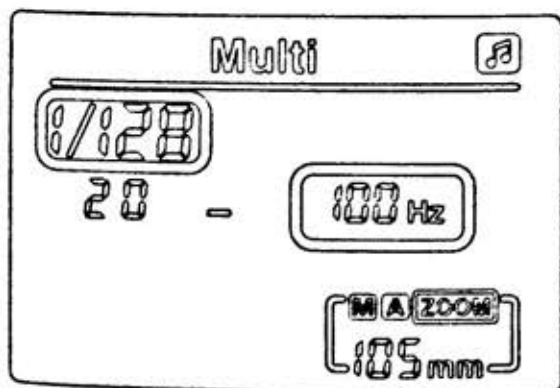

The number of flashes set

Select the Settings button group **【MIDDLE】** key to display  flashing, Select the Settings button group **【LEFT】** **【RIGHT】** key to set the number of flashes, the available number of flashes for 1-40. After Values setted and then select the Settings button group **【MIDDLE】** key to confirm.

Exposure power setting

Press select the Settings button group **【MIDDLE】** key until LCD display  flashing. Select the Settings button group **【LEFT】** **【RIGHT】** key to set the flash power. After Values is setted and then select the Settings button group **【MIDDLE】** key to confirm.

Flash power and the number of flash relational tables

Flash power	1-128	1-64	1-132	1-16	1-8	1-4
Flash number	1-40	1-20	1-12	1-8	1-4	1-2

【ZOOM】 Zoom settings

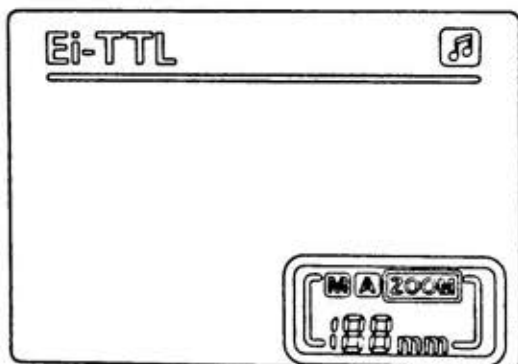

Press the zoom button **【ZOOM】** key to display the zoom data flashing, Select the Settings button group **【LEFT】** **【RIGHT】** key to set the appropriate focal length value, After focal length value have been setted, Press **【ZOOM】** key to confirm.

Select the Settings button group **【RIGHT】** key, focus values increase sequentially.

Select the Settings button group **【LEFT】** key, focus values decrease sequentially.

A	M	M	M	M	M	M	M	M	M	M
Automatic	18	24	28	35	50	70	85	105	135	180

Wireless flash mode

With multiple speedlite having the wireless flash feature, you can create various lighting effects with the same ease as using normal TTL autoflash.

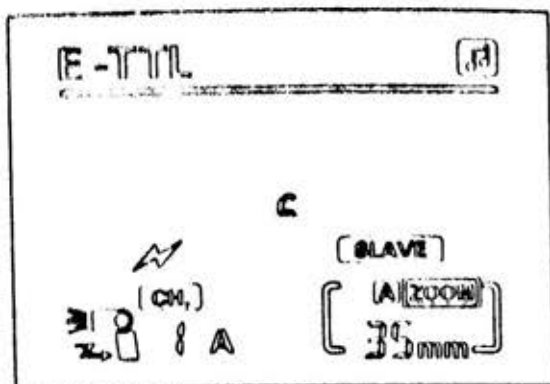

C means that only to receive Canon wireless flash signal, avoid N signal interference;

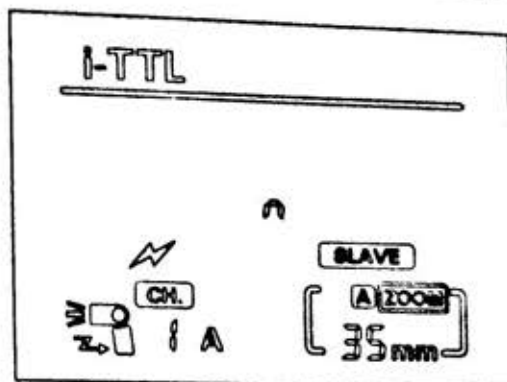

N means that only to receive Nikon Remote flash signal, avoid C signal interference;

1. Set the speedlite to wireless flash mode by press wireless selection key, When the LCD screen display **SLAVE C**. Press the Wireless select button. The flash will switch between **SLAVE C/SLAVE N/S1/S2** as well as normal flash. The **SLAVE C/SLAVE N/S1/S2** four models as the slave unit from machine use, create different lighting effect.

2. The Master unit

The Master speedlite set any flash exposure compensation setting, flash exposure bracketing, exposure lock, manual flash stroboscopic flash, information settings will be automatically transferred to this speedlite.

3. Press **[ZOOM]** key to **[CH.]** . Flashing, press **[LEFT]** **[RIGHT]** key to set the wireless channel, Press **[middle]** key to confirm, exit the settings.

4. Press **[ZOOM]** key to **A/B/C** flashing, press **[LEFT]** **[RIGHT]** key to set the group. Press **[middle]** key to confirm exit the settings.

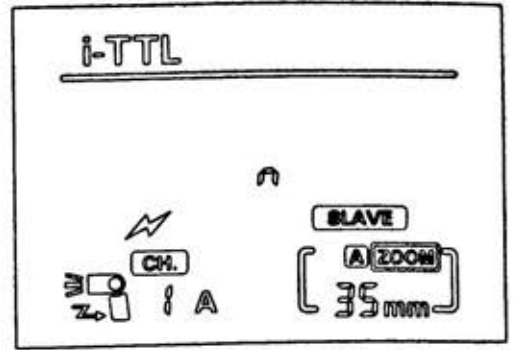
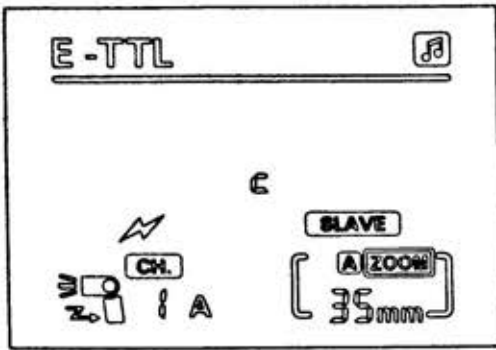

SLAVE C indicate receiving wireless flash signals from the canon 7D /60D/600D camera flash and 580EX II,600EX,ST-E2.**SLAVE N** indicate received C instruction form Nikon camera as well as C instruction signal of SB-900/800/700, SU-800 .**SLAVE C/N** supports 4 channel, 3 different groups,TTL,manual and stroboscopic wireless flash.Using this mode by rotating flash lamp,It make the wireless trigger sensors toward the master speedlite.Before shooting,this speedlite and the Master speedlite should be arranged in the same channel.This speedlite as the slave unit,press the [ZOOM] button until the channel or category flicker,respectively setting the slave unit Communication channels (1, 2, 3, 4) and the slave unit group (A, B, C).When work in Slave units,Focal length is not controlled by the Master flash light, need to adjust manually.The flash mode of brightness and completely controlled by the Master control unit,and to display the received information.

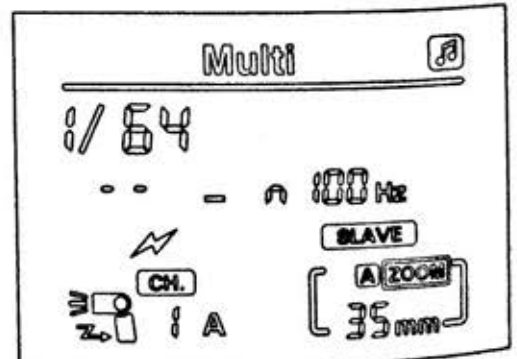
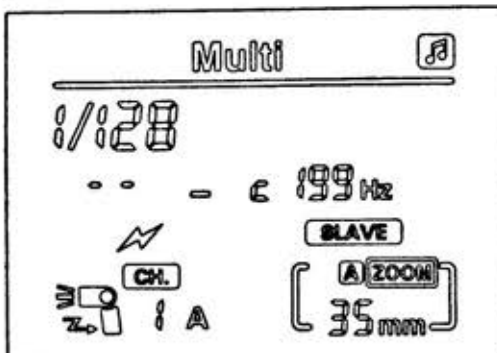
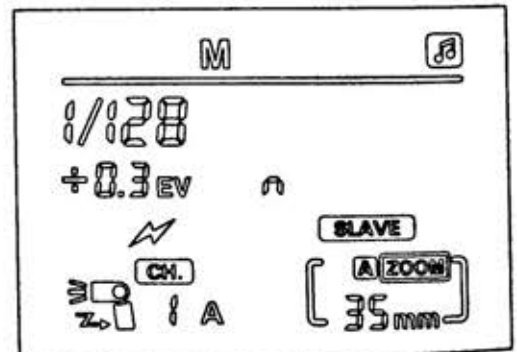
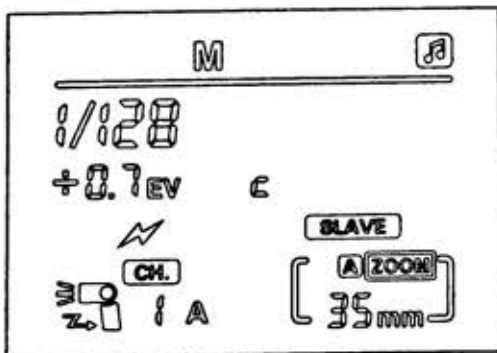

Light flashing mode S1 S2

When need to form a flash unit off-camera flash. You can set the slave light in S1 or S2. When use S1, S2 mode, the sensor against the master lights by rotating the flash head.

Set light flashing mode S1 S2:

1. Press wireless select button until the LCD display S1, S2.

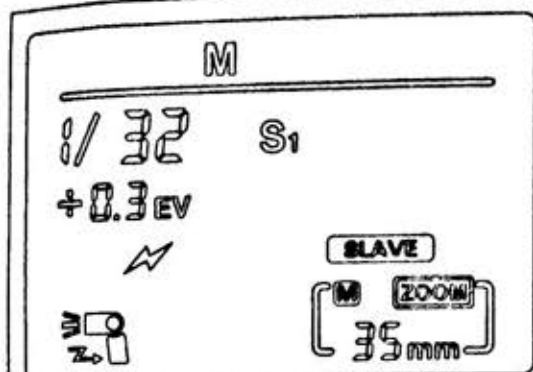

(1) When you press the Settings button **【RIGHT】** keys, the compensation value in turn increases.

Icon: 1/128 → 1/64 → 1/32 → ... → 1/1

When you press the "Select the Settings button" **【LEFT】** key the compensation value in turn decreases.

Icon: 1/128 → 1/64 → 1/32 → ... → 1/1

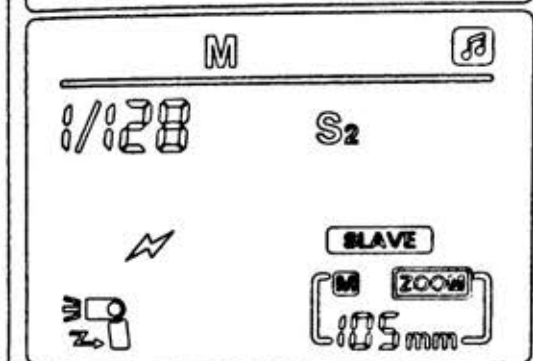

(2) Select Settings button **【UP】**

【DOWN】 function key to fine-tune the flash power value.

Icon: 0EV → +0.3EV → +0.7EV

2. Press the wireless select button, can make flash into the S1, S2 mode, these two modes suited as from the the machine auxiliary lamp role to create a variety of lighting effects. They are suitable for manual flash environment and TTL flash environment. In these two mode to adjust the output brightness is the same as M mode, only need to operate in the **【Left】** **【Right】** **【Up】** **【Down】** and **【Middle】** button.

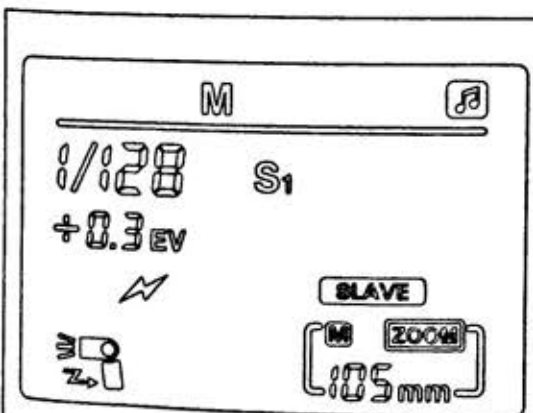

S1 Mode:

It is suitable for manual flash environment, It will senses every flash of the main flash and synchronous trigger flash, It is consist effect for use wireless flash. To properly use this mode, your master flash should be set in the manual flash and neither be used with pre-flash TTL flash system, Nor be used with multiple flash red-eye reduction function.

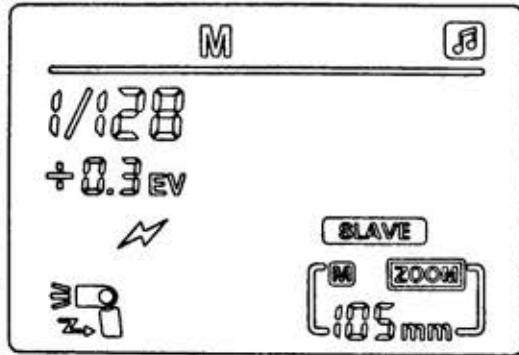

S2 Mode:

It is suitable for TTL flash mode, also known as the 'pre-flash cancel mode', the mode can ignore the pre-flash TTL flash and synchronization with the main flash, so you can support the Master flash in TTL mode.

If the auxiliary lamp selection S1/S2 mode can not properly synchronized with the master flash, make sure that the flash mode of the master flash is right. Sensing modes and power output should be set correctly.

Please note that to avoid the following situations when use the S1 S2 mode: The Master speedlite using in the red-eye reduction function and modeling; The master speedlite using the remote flash mode (Nikon) or wireless flash mode (Canon); Use ST-E2 as flash controller.

Note: When the flash under Slave mode, Mode key is invalid, It need to withdraw from the Slave mode so that can change the mode manually. When the Nikon version speedlite setting in the Slave mode, It can't connect with the camera, It need withdraw Slave mode so that can connect. When the canon version speedlite setting in the Slave mode, connecting with the camera. It will automatically exit the Slave mode into E-TTL mode.

“” Rear-curtain sync settings

Rear-curtain sync: With a slow shutter speed, you can create a light trail following the subject, the flash fires right before the shutter closes.

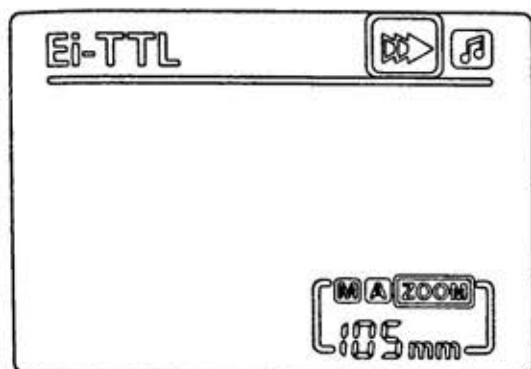

1. Canon version speedlite, Under E-TTL, M mode, If you want to correct use the Rear-curtain sync function, Press the **【Rear-curtain sync/Ordinary flashlight】** switch key to ordinary flash (no, display) → Rear-curtain sync () to open the corresponding function.
2. Nikon version speedlite, If you need the Rear-certain synchronous mode, open the Rear-curtain sync on the camera Menu. (There is no display on the speedlite)

Note: To correct use the Rear-curtain sync, please properly set camera flash mode and shutter speed.

Multi-lamp lighting applications

1. Wireless lighting light instructions

Multi stage flash, wireless flash configuration

You can create two or three slave groups to complete the multi-directional shooting demand. And a main controlling flash setting TTL auto flash shooting flash ratio, manual flash output, stroboscopic etc.

(1) Using this speedlite make two slave groups Wireless flash

Set of wireless options: there are **SLAVE c/SLAVE n** options

A communication channel is provided: 1, 2, 3, 4

Set group: two speedlite are set to A, B groups

Set the Master unit: a communication channel is provided: set the flash ratio of Master unit A:B or A:B:C, to flash shooting

(2) The speedlite make three slave groups Wireless flash

Set of wireless options: there are **SLAVE c/SLAVE n** options

A communication channel is provided: 1, 2, 3, 4

Set group: three speedlite are divided into A, B, C groups

A main control unit and shooting: a communication channel is provided: the main control unit of the flash ratio is <A:B:C>.

Pressed to the Master unit to test flash, test the flash normal or no.

If the slave unit does not flash, please check the speedlite toward the master unit angle and distance to the master unit

Note: the Master unit if you set the <RATIO A:B>, set as a slave unit <C> group will not flash. If the group of three speedlite is set to <A>, then they will be used as a flashlight acceptor slave control by groups control unit.

2. Wireless induction lighting light

Using built-in seedlite or external speedlite as the Master speedlite. Use the speedlite by different type to do different angle.

When be used, wireless signal can be refelct by wall in door. So there will be more space to place the Slave speedlite.

The improved wireless triggering sensor trigger have higher sensor sensitivity, S1,S2 mode can work in the outdoor environment, wireless trigger sensing have distance of 15 meters.

Using the Slave speedlite, please test S1 or S2 model if it is synchronous before shooting.

Please don't put any arriers between the Master and Slave speedlite. The arrier prevent to send wireless light signal.

When used outdoor, the optic control sensor should be towarded to the Master speedlite, The speedlite can't be used under sunshine. If your speedlite's shining postition had clashed. Please whirl the head of sppedlite to satisfy photography request.

Bounce flash

When the flash head pointing to the wall or ceiling, flash will be wall reflection. When it is illuminate the subject, this can reduce the shadows around the subject and get more natural photographic effects

High-speed burst mode

The speedlite have the high-speed burst function. Please set camera into burst mode, and then shooting.

Please attention: the photos quantity in connection with brightness. So please keep enough battery power.

Set position and operating range:

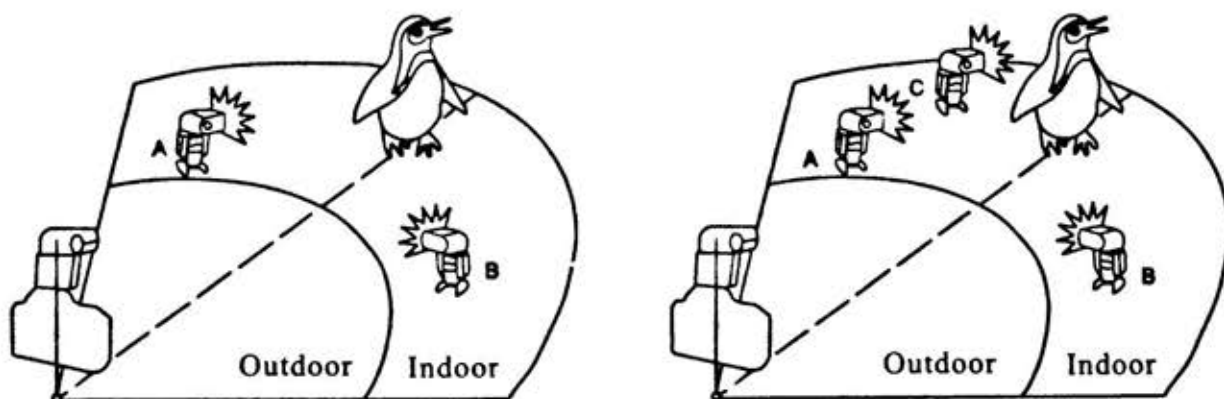

The camera menu access (only Canon newer models)

It may be operated by a camera flash menu access in support of E-TTL (Canon) the newest camera. In the flash control menu "External flash function settings" and "External flash Custom settings" can set the flash parameters; such as switching E-TTL mode / manual flash mode and multiple flash mode (Multi), wireless flash setting, exposure bracketing, exposure compensation, focal length and advanced options function etc..

Voice prompts:

Different sound ways will prompt the different working conditions of the speedlite so as to make you focus on shooting only.

Long press the custom function setting button /Fn to custom settings the buzzer switch will be turned on or off.

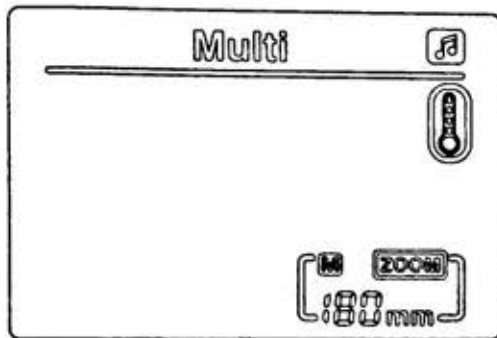

1. A long ring: call back to complete
2. Two short sound: boot or call back to complete normal flash.
3. Two long beeps: flash call back unfinished.
4. Three short blasts: 30 minutes without operation automatically turn off or shut down.
5. Four short beeps: low battery shutdown (call back timeout).
6. The display will show continuous shortness beep: flash overheating, to enter the overheating protection .enter overheating protection the display will show overheating protection icon.

Backlight tips

1. When the first time press LCD backlight switch, the LCD backlight on. Then press LCD backlight the LCD will under close status.
2. When the LCD backlight in standby mode about 15 seconds without any action, the speedlite will be automatically turns off and the backlight will be activated to save power and prevent power accidental discharge.

Custom function settings

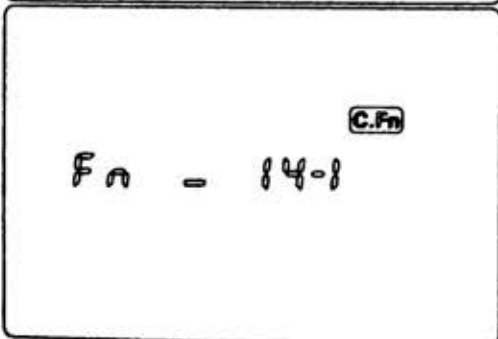
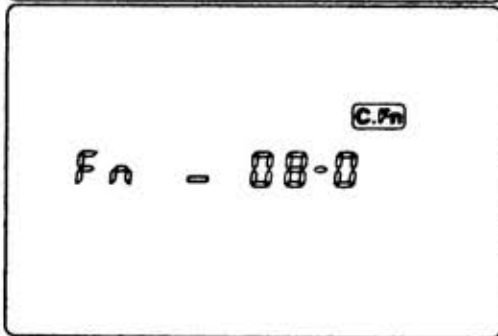
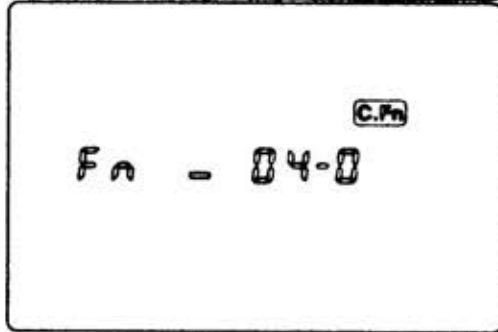
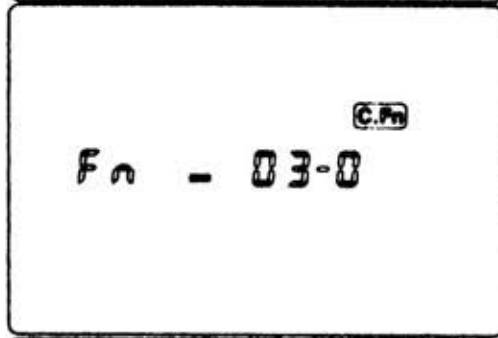
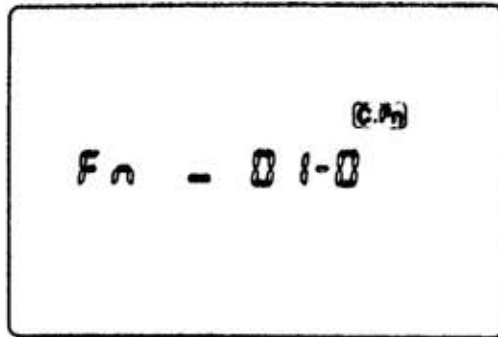

You can follow your shooting preferences custom flash function. Use a custom function to complete the set.

Press the "custom function setting button" /Fn to the shown on the left.

Choose the functionality they need, press **【up】** **【down】** key setting

Custom Function No.	Function	Set ID	Settings and descriptions
C.Fn-01	Auto power off	0	on
		1	off
C.Fn-03	Flash exposure bracketing auto cancel	0	on
		1	off
C.Fn-04	Flash exposure bracketing sequence	0	0----+
		1	--0--+
C.Fn-08	Af-assist beam firing	0	on
		1	off
C.Fn-14	Buzzer switch	0	on
		1	off

Note: Fn number of 00 ~ 13 options can be accessed through the camera menu of "External flash custom function Settings" to set up; The Numbers for: 00, 02, 05, 06, 07, 09, 10, 11, 12, 13 option has been disabled. (Internal Canon cameras menu)

Adjust speedlites head to slope Whirl angel and choose reflection palne

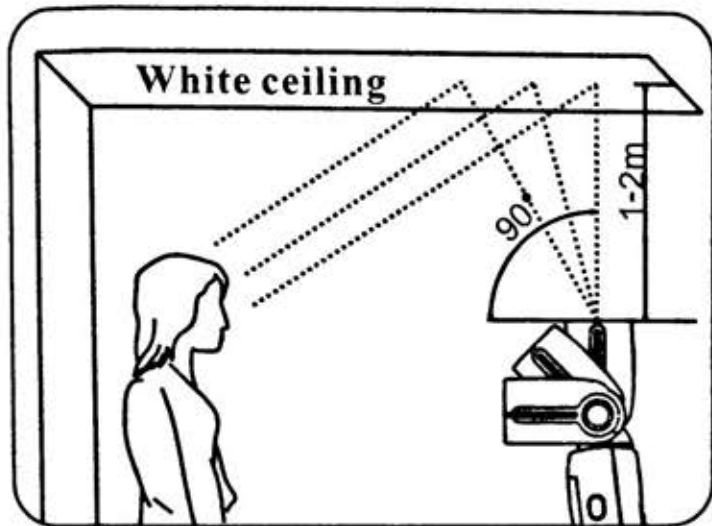

When the speedlite head pitch uped and the ceiling as a reflection,we can use the simplest to get the best effect. Holding the camera and horizontal turning plate to get the same effect.Please attention: Don't use the speedlite head's flash direct shine to the body.

The effective distance between speedlite head and reflection palne about form 1 m to 2 m. When shooting colour photos,please choose white or stong reflection to flashing.Else,shoot photos will be not very good and near the reflection palne's colour.

Using the lambency to shooting

Fix the lambency shade on the speedlite.The reflect lighting will be solw fire to cause the soft light to get no shadow.It will be the same effect as any camera in level or portrait position. When the speedlite in 60 degree,it wi

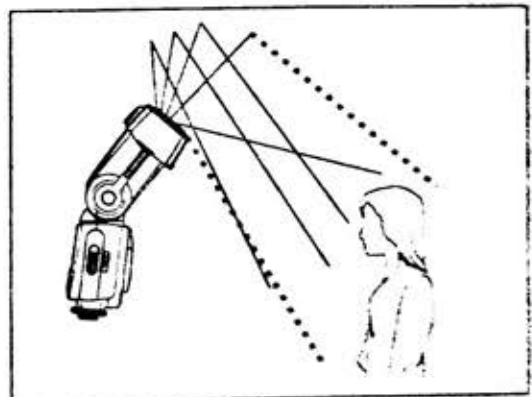
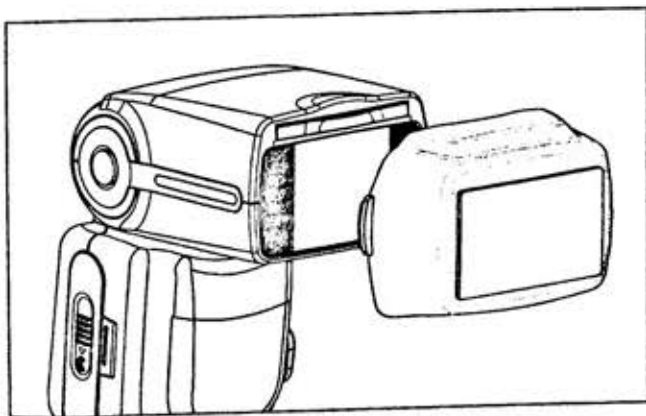

Using built-in reflect card

When under reflection flash shooting, using built-in reflect card to make the subject more bright, sharp, and to avoid lighting in front of the subject.

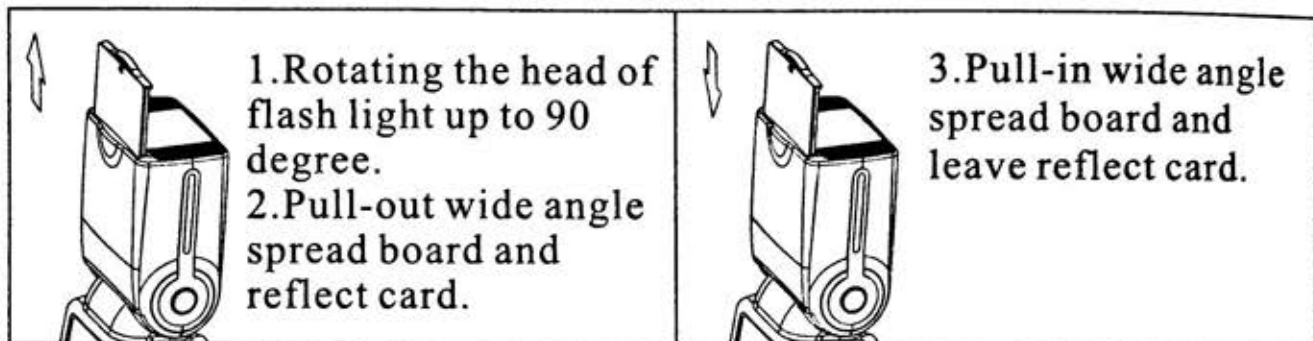
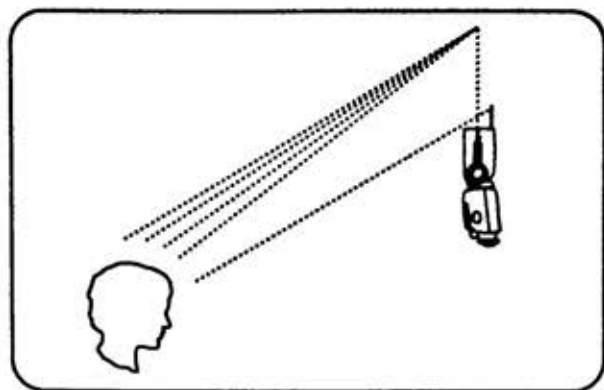

Using the built-in wide panel

When distance less than 2 m from camera to the subject, the wide panel to shooting to get nauter photos. Also, Built-in wide flash diffusion plate can be extended to wide-angle coverage.

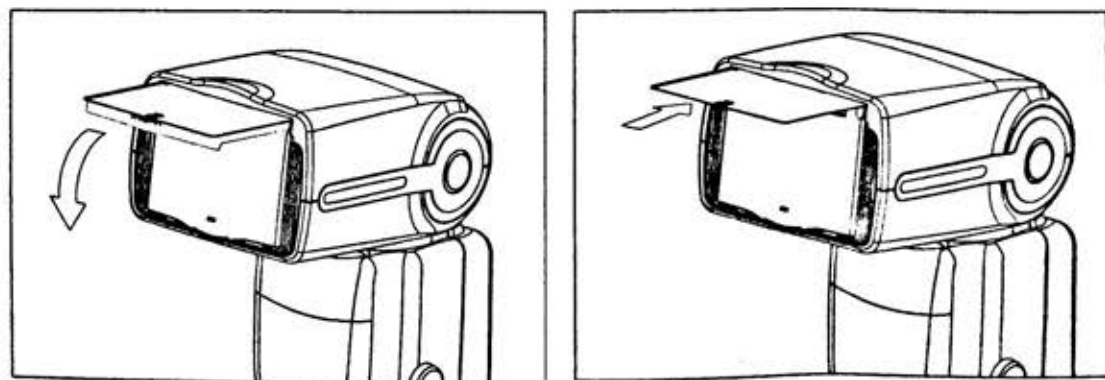

Specification

Circuit design: Insulated Gate Bipolar Transistor(IGBT)

Flash index: 56(ISO100,180mm)

Flash coverage: 18~180mm

Manual, Automatic Zoom

Swinging/Tilting flash head (bounce flash)

Flash mode : TTL, M, FEB, Slave, S1, S2, Multi

The wireless trigger: Wireless induction flash lighting

The wireless cited flash distance: Indoor 20-30 meters,
Outdoor 10-15 meters

Up and down whirl angle degree: -7~90degree

Left and right whirl angle degree: 0~180degree

Slave Group and Unit: 4 Slave communication channels (1,2,3,4)

3 Slave unit group(A,B,C)

Colour temperature: 5500K

Flash time: 1/200 seconds ~ 1/20000 seconds

Flash control: 1/128~1/1 step length is 0.3EV, Total 22 fine -tuning stalls.

Peripheral interface: Hot shoe, PC mount, External charge mount

Recycle time: 2.9 seconds

Power: 4pcs AA alkaline cell or AA Nickel-Hydrogen(NI-MH) battery

Lighting time: 100~1500 times

Additional function: PC synchronous, Sniff mode, Over temperature protection

Volume: 200*75*57mm

Net Weight: 375g

Accessories

Protect bag: 1 pcs

Mini stand: 1 pcs

Reflector: 1 pcs

Instruction manual: 1 pcs

