

THORENS

INSTRUCTION MANUAL

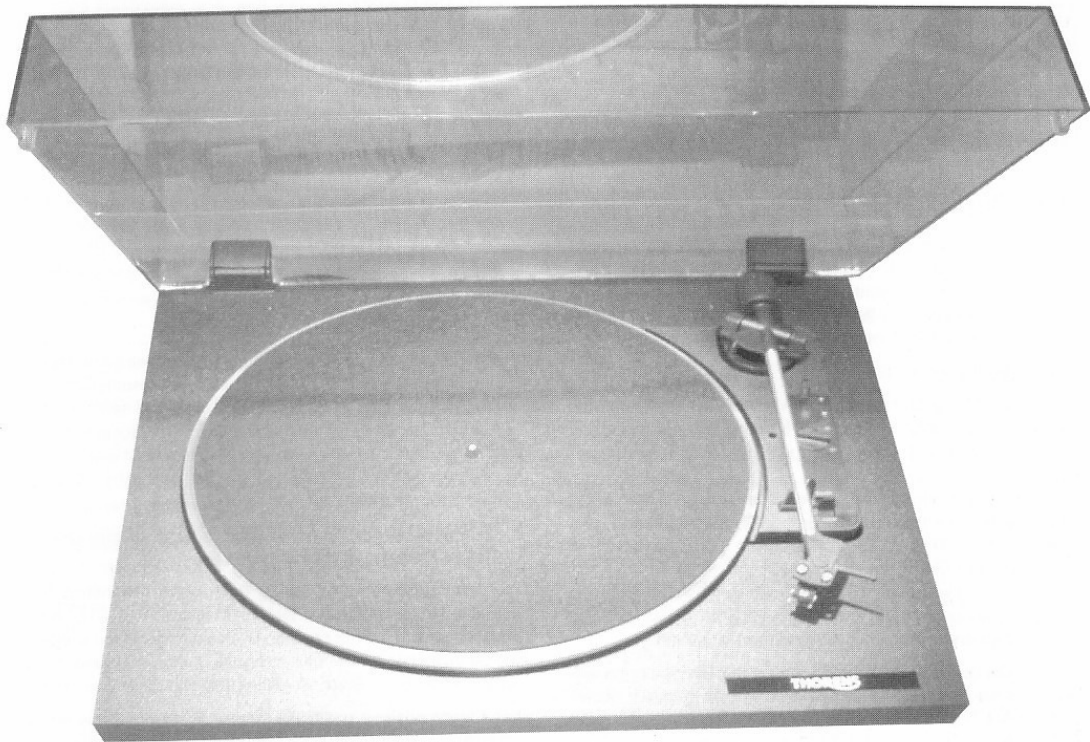

TD 158

Contents	Page
Thorens Factory Warranty	2
Technical Specification	3
Unpacking and Assembly	4
Electrical Connections and Installation	4
Operation of the TD 158	5/6
Tonearm and Pickup Cartridge	7

Dear THORENS customer,

Thank you very much for your confidence in our product, the record player **TD 158**. With the purchase of this device you have acquired a precision instrument for the purpose of playing back analogue records. This appliance however requires your attention with respect to set-up, placement and handling in order to achieve a flawless operation. The **TD 158** has been designed and assembled completely in Germany which will guarantee you the highest quality to be maintained for years to come. Understandably, you want to listen to your beloved records right away but we strongly advise that you read these instructions attentively before proceeding with the setup, simply to ensure long-lasting listening pleasure. We have spared no efforts to pack all necessary information and comprehensive guidance into this manual, yet in the event that you have any further queries regarding your new record player please do not hesitate to ask your THORENS dealer for further assistance.

**Sincerely yours,
THORENS TEAM**

WARRANTY

Legal warranty directives and regulations are to be applied here. In case a failure or malfunction occurs in your record player during the warranty period please inform your THORENS dealer or general representative and describe the malfunction that has occurred. If the malfunction cannot be remedied on site by sending you the respective user-serviceable spare part, you are kindly requested to send the unit in its original shipping box to the THORENS representative in your country. If the original shipping box is no longer in your possession your THORENS representative will be in the position to supply a new one for a small charge. Shipping costs to THORENS or to an authorized service centre must be prepaid because otherwise the parcel will be rejected upon arrival. After repair or service the unit will be returned to you free of charge. Whenever you ship this turntable kindly use the screws for the security during transportation.

Any damage or malfunction caused by failure to observe the instructions contained in this manual as well as damages occurred in transport or shipping are not covered by this warranty. This warranty only covers the turntable and motor including power supply and mains transformer. The tone arm and pick-up cartridge are covered by the warranty of the respective manufacturer thereof.

In the event that you have further queries or need assistance please do not hesitate to contact your authorised THORENS service.

Technical Data

Measured values = typical values

Belt drive	electronic-controlled DC motor
Mains voltage (Mains set)	155 V / 60 Hz
Line frequency	50 / 60 Hz
Power requirement	1,5 W
Platter speeds	33 $\frac{1}{3}$, 45 U / min
Wow and flutter (DIN/WRMS)	± 0,10 / 0,04 %
Platter	Ø 304 mm
distortion-free aluminium tubular tonearm	
Signal-to-noise ratio (DIN 45 500) Rumble unweighted signal-to-noise ratio Rumble weightes signal-to noise ratio	42 dB 65 dB
Effective tonearm length	211 mm
Offset angle	26°
Overhang	19,5 mm
Tangential tracking error	0,15° / cm Rad.
Cartridge HiFi DIN 45 500 rot R right channel grün RG right channel ground blau GL left channel ground weiß L left channel	DMS 251 S
Diamant stylus conical	DMS 251 S 15 µm
Tracking force	20 mN (22,5 - 27,5 nM)
Frequency range	20 Hz - 18000 Hz
Output	4 mV / 5 cms ⁻¹ / 1 kHz
Compliance horizontal vertical	16 µm / mN 18 µm / mN
Cartridge weight	5 g
Total capacitance Tonearm leads and audio-cables	ca. 160 pF
Dimensions (W x H x D) (mm)	420 x 119 x 360

WARNING!

To prevent fire or shock hazard, do not expose this product rain or moisture

Unpacking and set - up

Take the record player and all accessories out of the carton. Remove the two transportation locks (Fig. 1) by applying lateral pressure. The locks are located underneath the platter at the front left and at the rear right. Put the platter onto the sub-platter and press down the two safety springs until they set into the groove of the platter spindle (Fig. 2). Insert each hinge into the respective recess (Fig. 3). Hold the dust cover parallel to the hinges (opening angle approximately 60°), insert and push as far as it will go. Being in this position the dust cover may be removed at any time.

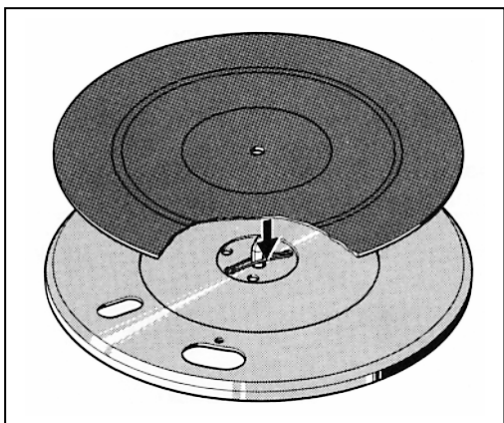

Fig. 2

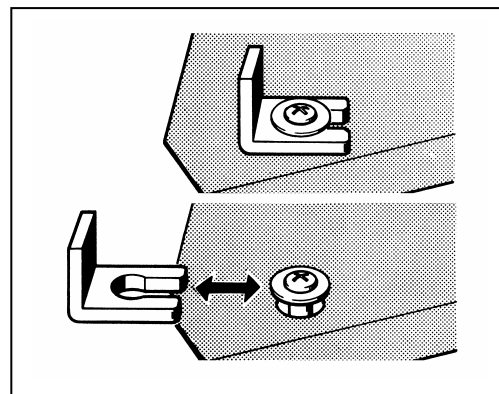

Fig. 1

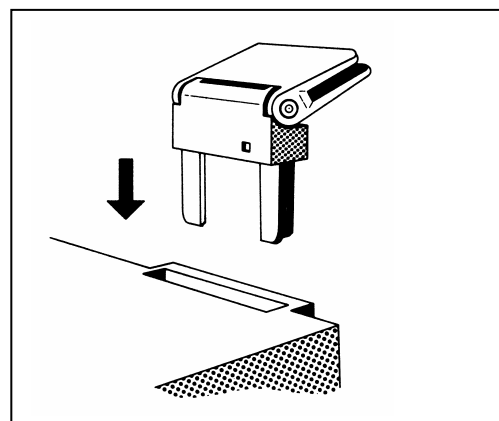

Fig. 3

IMPORTANT!

ALWAYS KEEP THE SHIPPING CARTON IN A DRY PLACE FOR THE EVENT THAT THE RECORD PLAYER HAS TO BE PACKED AGAIN FOR TRANSPORTATION. IN THIS CASE IT IS IMPORTANT TO DETACH THE PLAGTER AND PUT IT ON THE BOTTOM OF THE SHIPPINGBOX; JUST AS IT WAS ORIGINALLY DELIVERED TO YOU.

Electrical connections

By choosing the appropriate THORENS mains transformer this record player can be operated from nearly all existing public mains supplies. The low-voltage plug on the cable that is coming from the mains transformer unit is to be inserted into jack **17** (Fig. 4) at the rear side of the record player.

The stereo signal leads have two phono plugs which are also known as "Cinch" or RCA-plugs. They are marked with either the letter "L" for the left channel or "R" for the right channel. If these letters are missing then most likely the right channel is marked red, perhaps by featuring a red plug at both ends, and the left channel is marked white or black accordingly. The RCA-plugs are inserted into the phono input jacks of an amplifier or receiver. The separate single litz-wire is making a connection to ground and is to be fastened underneath the ground screw of the amplifier or receiver

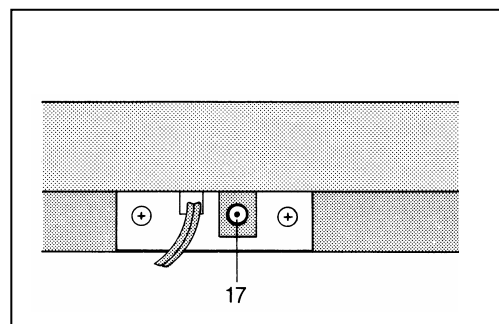

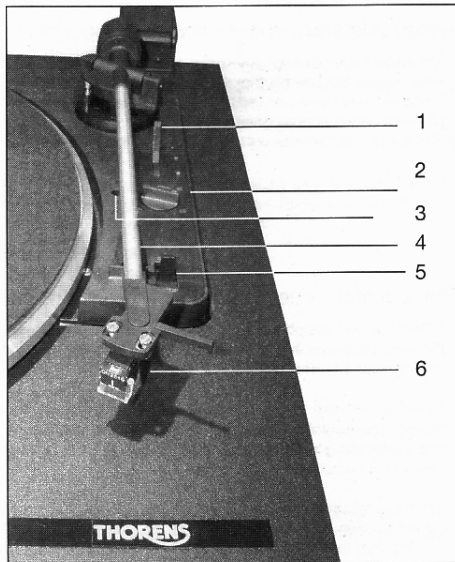

- 1 Cueing lift lever
- 2 Speed selector
- 3 turning screw
- 4 Tone arm support with tone arm lock
- 5 Automatic Start - Stop switch / moving knob
- 6 Stylus

Stylus DN 251 S

The stylus is subject to natural wear and tear during normal playing. Therefore, we recommend you occasionally check the stylus and, in the case of diamond styli, this should be carried out after approximately 300 playing hours. Worn or damaged (splintered) styli chisel the modulation from the grooves and destroy records. Therefore, only use the stylus types recommended in the technical data of the cartridge as replacement cartridges. Imitated styli result in audible quality losses and increased wear and tear of records. Pull off the stylus slanting downwards. Insert the stylus in the reverse mode (Fig 6).

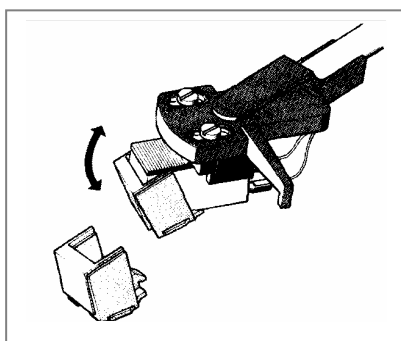

Fig. 6

Automatic start, speed selection

- The record diameter for automatic start is also preselected when the record speed 33 or 45 rpm (**2**) is selected.
- Remove the stylus guard cap by pulling it forwards and disengage the tone arm (**4**)
- Set switch **5** to **Start**.

Manual start, cue control

- Select the required platter speed, 33 or 45 rpm, by means of the switch (2), swivel the stylus protection cap upwards, set the cueing lever (1) to position ▼.
- Now position the tone arm over the lead-in groove of the record. The tone arm is now lowered slowly onto the record using the cueing lever (1). The tone arm is lowered slowly, thus preventing damage to your records ▼.
- The tone arm can be raised at any position, also for brief interruptions when playing, by means of the cue control lever (cueing lever in position ▼) The platter continues to rotate in this case.

Stop

After reaching the lead-out groove the tone arm will be automatically lifted up and returned to its rest. The motor is switched off. You can also switch off the record player by either moving knob (**5**) into position **Stop**, or by raising lift-lever (**1**) into position ▼ and returning the tone arm manually to its rest.

Adjusting the start position of the tone arm

The start position of the tone arm has been adjusted in the factory. However if there is a deviation it may be readjusted by turning screw (**3**) to either left or right until the stylus can be lowered exactly at the lead-in groove of the record.

Mounting or exchanging a pick-up cartridge

Instead of the factory-supplied pick-up cartridge any other cartridge with standard half-inch mounting holes and a weight between 3 and 10 grams can be installed.

Unscrew the cartridge and carefully remove the coloured signal leads from the cartridge pins with a pair of tweezers. Screw the new cartridge onto the head shell but do not tighten. Attach the leads to the pins while observing the correct coding:

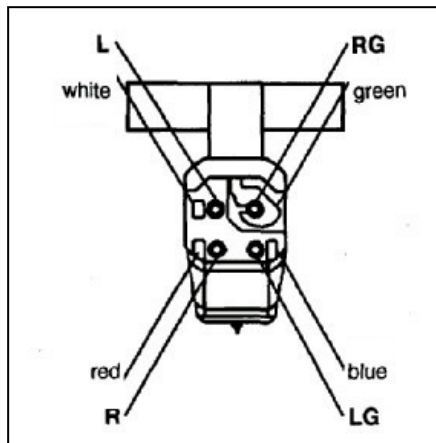

Fig. 8

R	=	red	right channel
RG	=	green	right channel ground
L	=	white	left channel
LG	=	blue	left channel ground

Electrical Safety

This device is in conformity with international safety regulations (IEC 65) and EC regulations 76/499/EWG.

ATTENTION!

During these mounting and adjustment procedures you must be very careful not to damage the delicate stylus and cantilever by uncontrolled and brisk movements.

THORENS

Thorens Export Company Ltd.

Im Hübel 1, CH-4304 Giebenach – Basel / Switzerland

Tel. ++41 (0) 61 – 8 13 03 37 Fax Tel. ++41 (0) 61 – 8 13 03 39

Internet: <http://www.thorens.ch>, Email: info@thorens.ch