

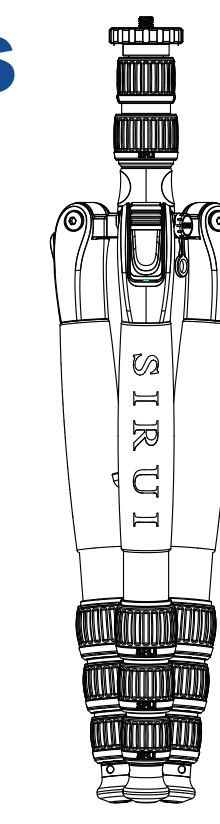

SIRUI, Capturing your Imagination!

Instructions

T-S Series Tripod



SIRUI WEBSITE

GUANGDONG SIRUI OPTICAL CO.,LTD.
Add: The Third Industrial District, Wuguishan Town, Zhongshan City, Guangdong, China (Zip Code: 528458)
Tel: 0760-88897373 Fax: 0760-88207062
E-mail: info@sirui-photo.com Website: www.sirui.com

1. Know the Product

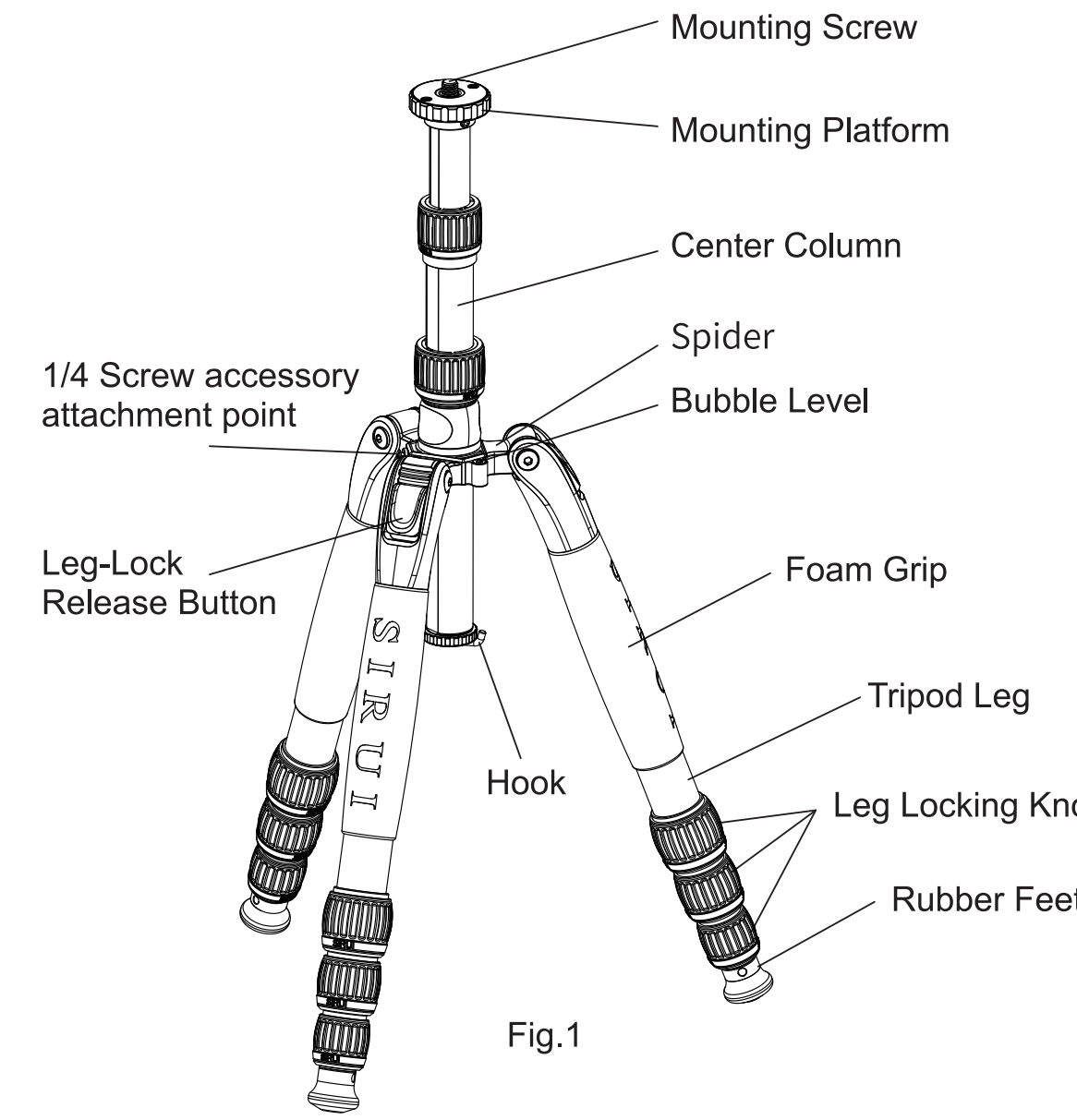

2. Leg Angle Adjustments and Folding

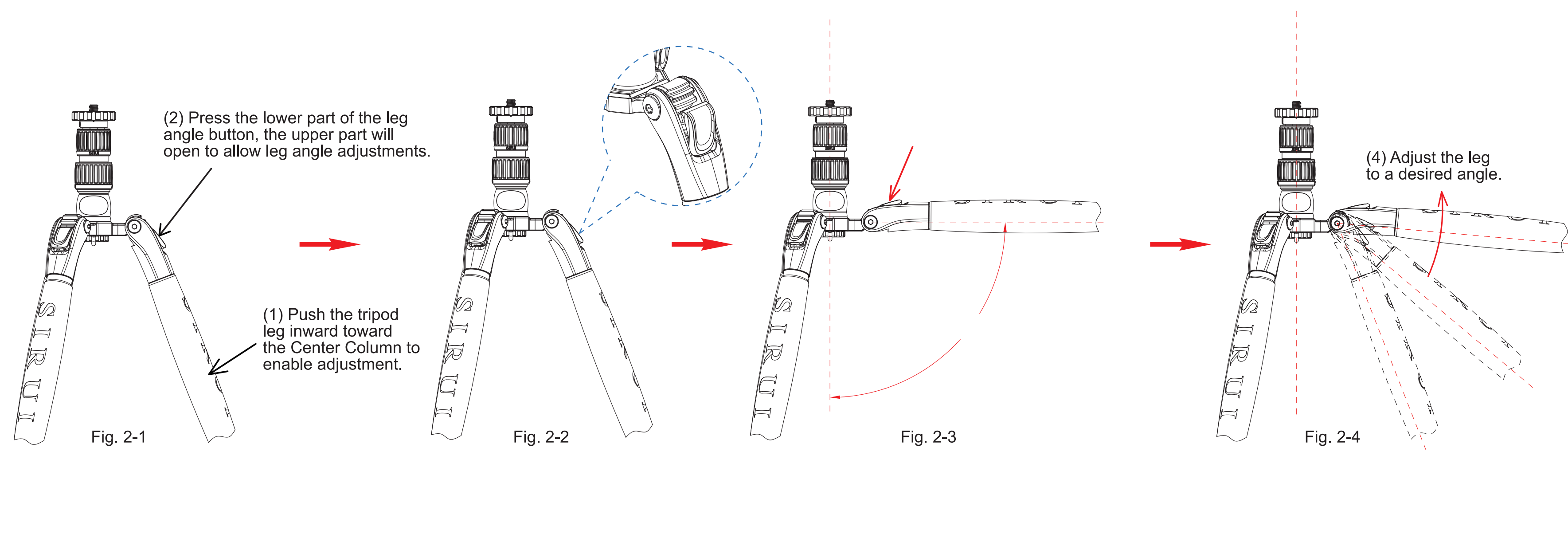

3. Extend or Retract the Tripod Legs

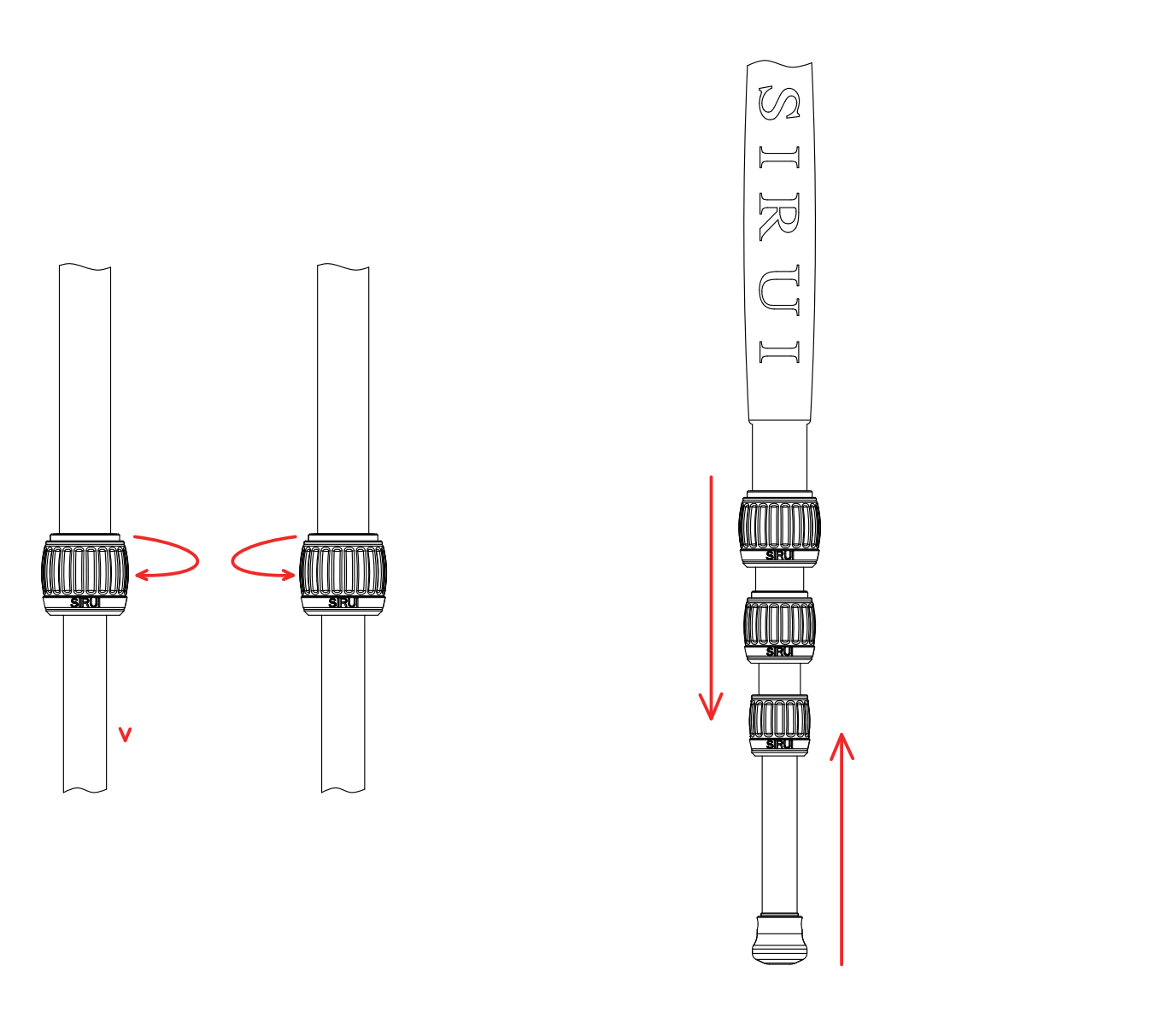

1. Know your Product (Fig.1)
2. Leg Angle Adjustments and Folding
The Tripod can be adjusted to 3 angles (22°, 52°, 82°). Press the button and lift up the leg to about 90°, the button will automatically click back in place and lock the leg angle automatically. Close or fold up the tripod legs as Fig.2-1 to Fig.2-6.
3. Extend or Retract the Tripod Legs (Fig.3-1 and Fig.3-2)
Loosen the Leg Lock Knobs with 1/2 turn clockwise all at the same time or separately to extend the Leg Sections to the desired length, lock the Leg Sections by turning the Leg Lock Knobs counter-clockwise from large to small. Retract the Leg Sections from small to large by loosening or locking the Leg Lock Knobs.
4. Use of the Center Column (Fig.4-1 and Fig.4-)
The Center Column of the Tripod can be extended or retracted for adjusting the height, and can reverse or convert for low shooting.

5. Convert the Detachable Leg into a Monopod (Fig.5-1 to Fig.5-3)
The Detachable Leg of the Tripod can be converted into a Monopod, and connect with the Center Column for additional height of the Monopod.
6. Change the Rubber Feet to Spike (Fig.6-1 and Fig.6-2)
Loosen and remove the Rubber Feet for changing to Spike.
7. Use of Mounting Screw, Set Screw and 1/4 screw accessory mounting hole. (Fig.7)

Attention:
⚠ Do not exceed the recommended load limit of the head and/or tripod. (Please refer to product specifications.)
⚠ Please make sure that the locks are securely tightened when in use.
⚠ This product should not be used in environments that exceed the following conditions (-40 ~ +100°C/-40 ~ +212°F). And, when used in damp, dirty or dusty environments, please clean and dry thoroughly after use, to assure proper functioning in the future. It is not recommended to expose this product to saltwater. If exposed, please clean with mild soap and warm water and towel dry.
⚠ Please do not leave the equipment alone in a public place, which can be an inconvenience.
⚠ To protect your camera gear, please remove it from the tripod/ball head when transporting from place to place.
⚠ Please use a soft towel with warm water and mild soap to clean the locking system and gliding parts when necessary. Towel dry before storing the tripod.
⚠ Under most situations, there is no need to lubricate any parts of this product. The addition of most lubricants will gum up the mechanisms and reduce their normal gliding characteristics. Please call or email us if you have any questions or special needs.
⚠ Please keep this product away from all electrical power sources.

4. Use of the Dual-Stage Center Column

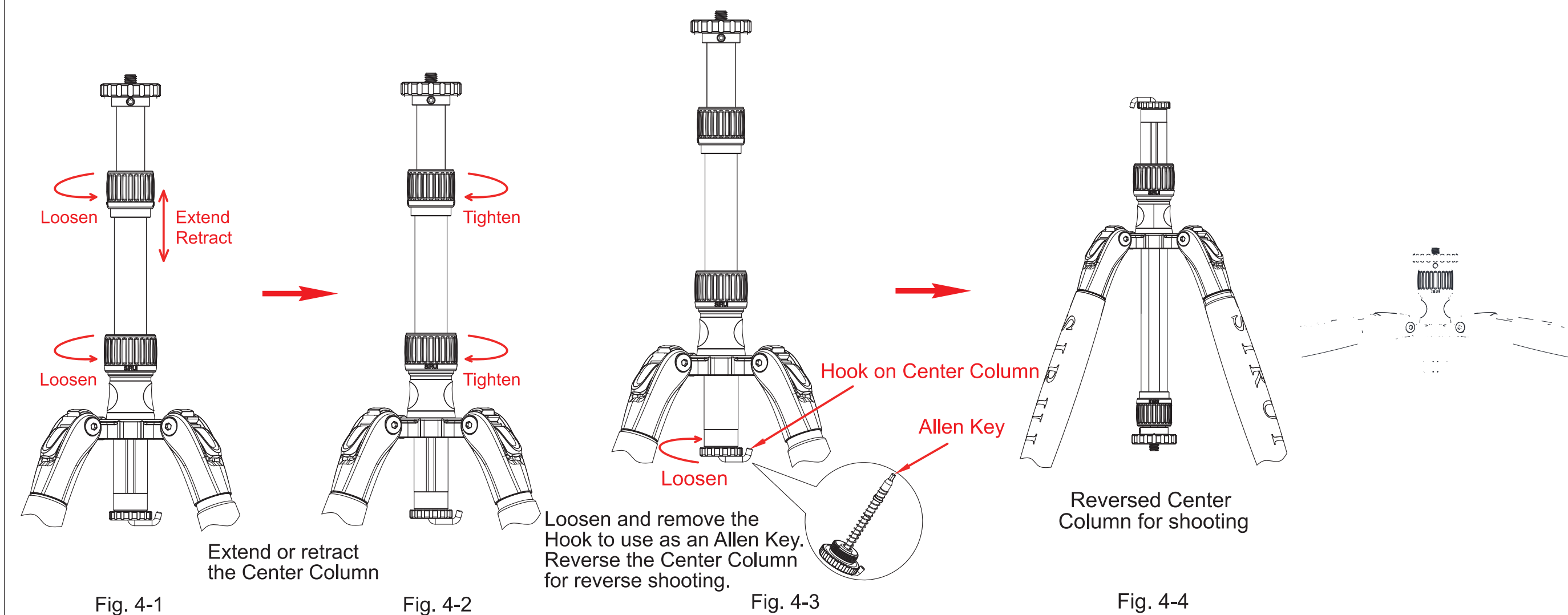

5. Convert the Detachable Leg into a Monopod

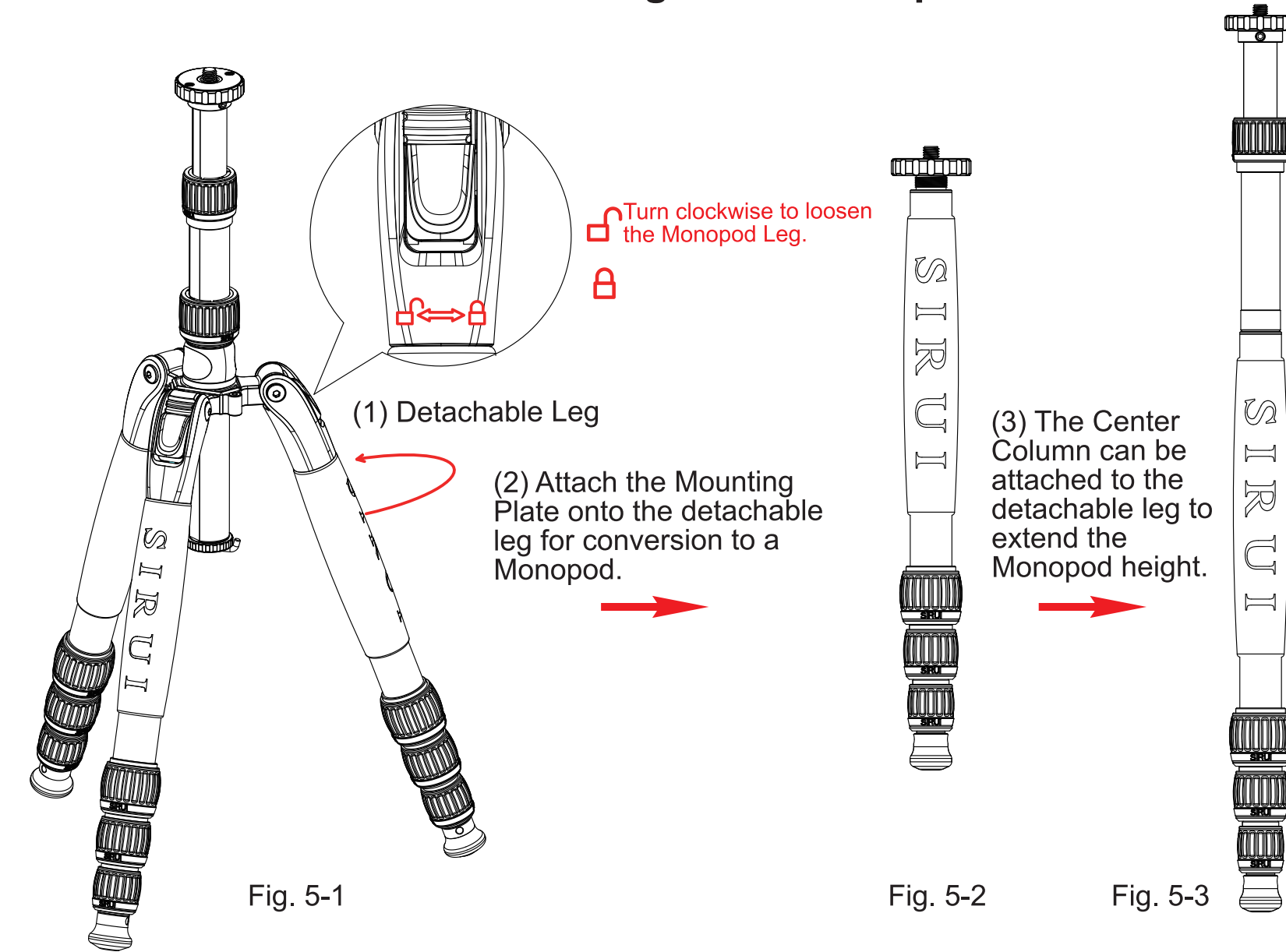

6. Change the Rubber Feet to Spiked Feet

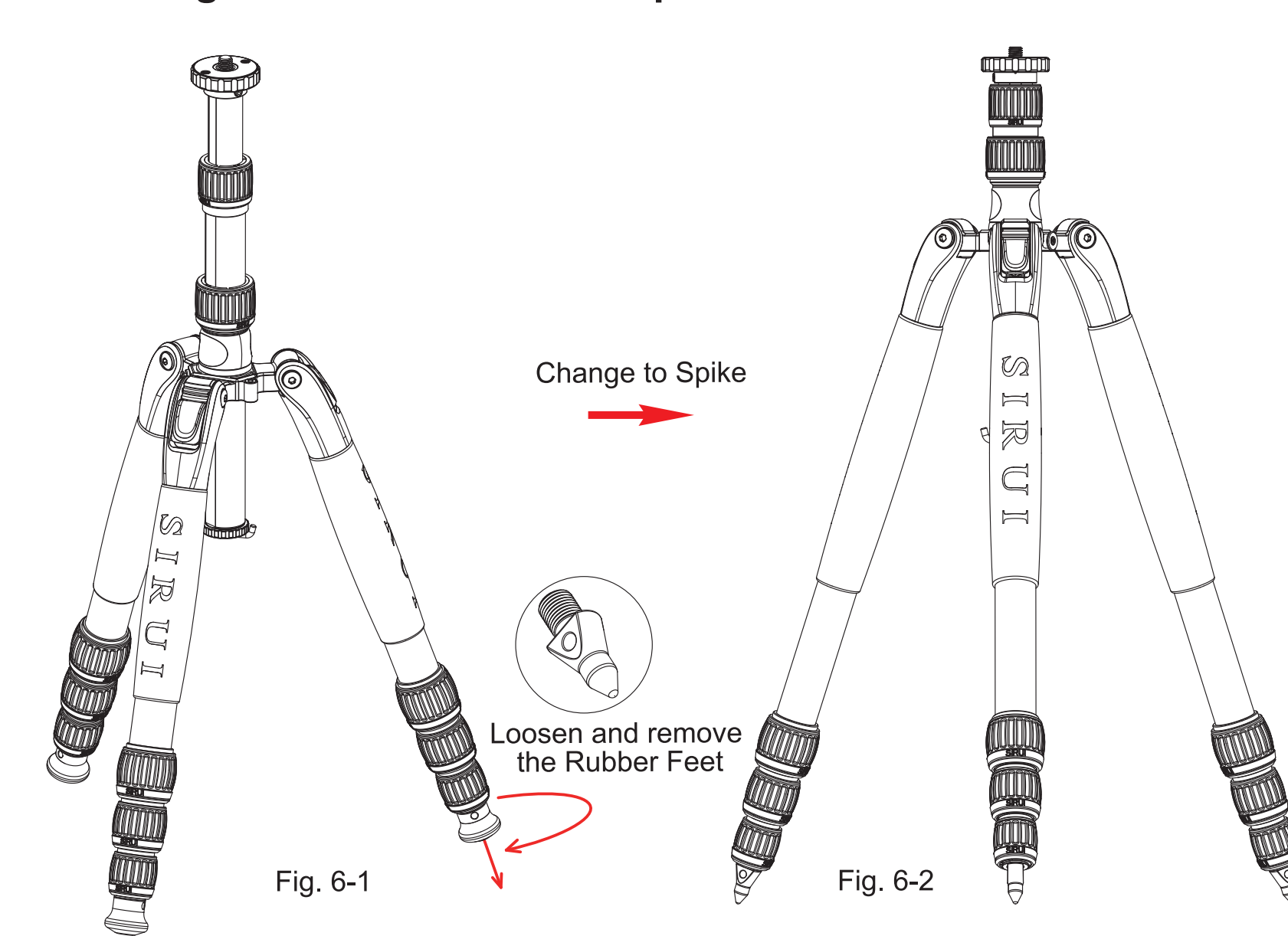

7. Use of Mounting Screw, Set Screw and 1/4 screw accessory mounting hole.

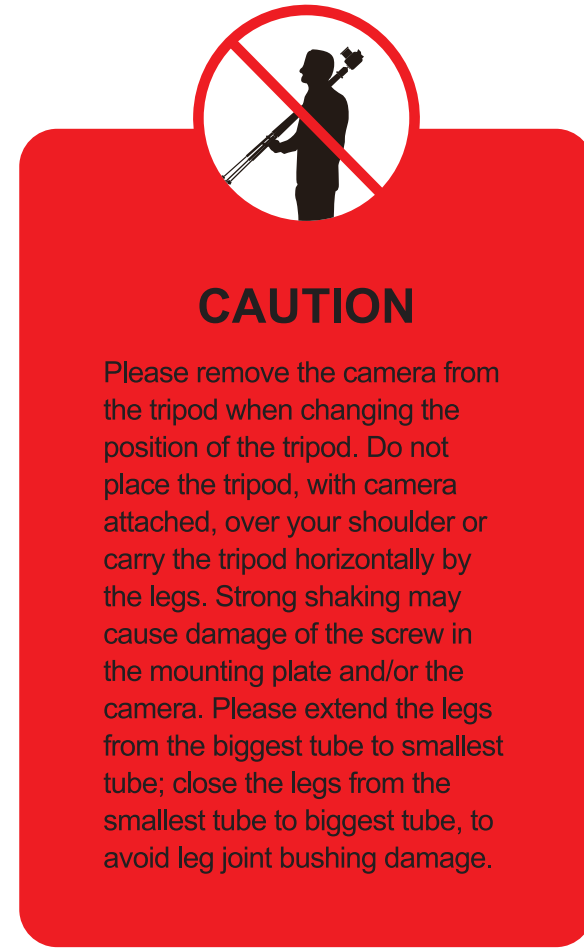
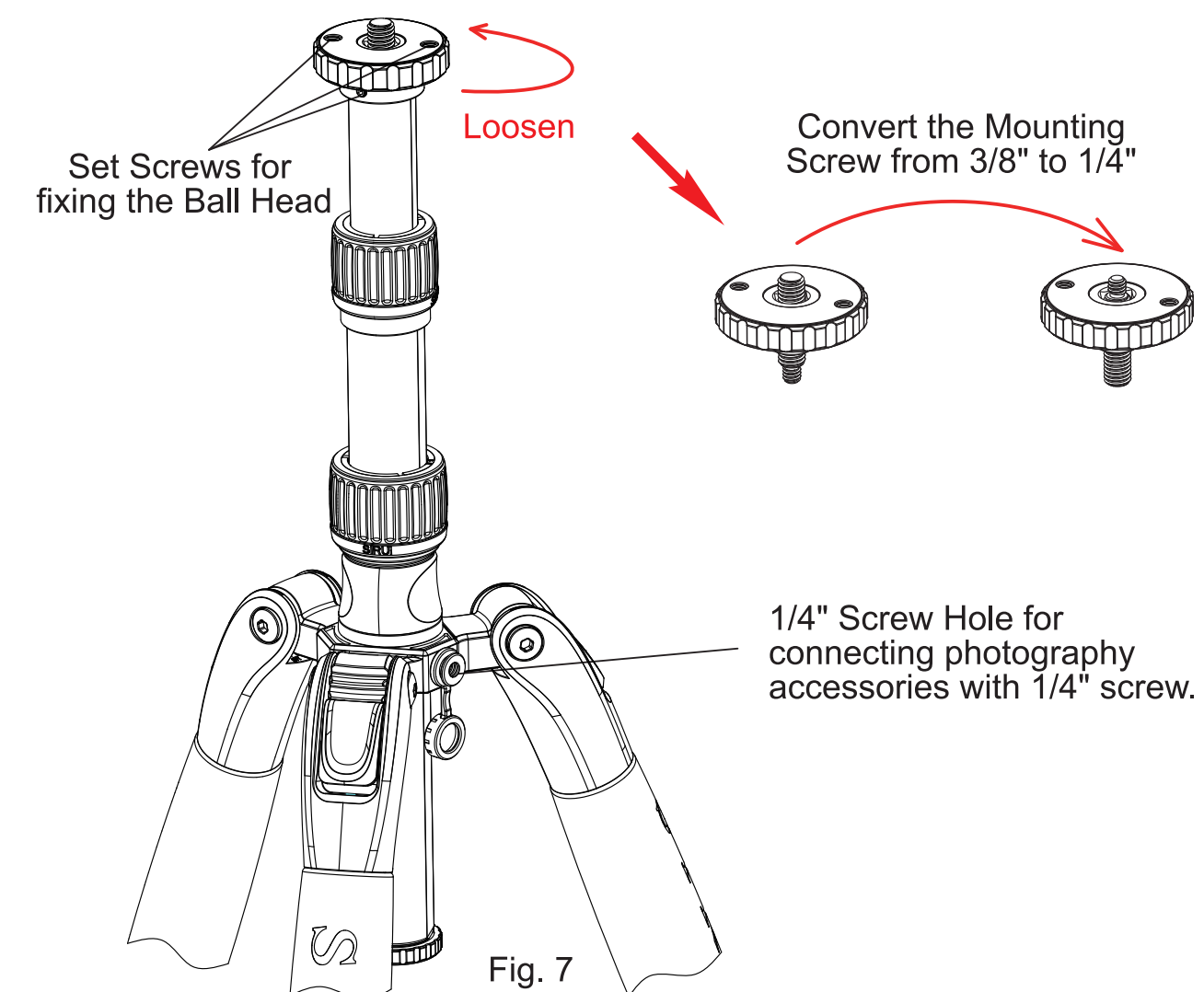

Please remove the camera from the tripod when changing the position of the tripod. Do not place the tripod, with camera attached, over your shoulder or carry the tripod horizontally by the legs. Strong shaking may cause damage of the screw in the mounting plate and/or the camera. Please extend the legs from the biggest tube to smallest tube; close the legs from the smallest tube to biggest tube, to avoid leg joint bushing damage.

Dear SIRUI Customer,
Thank you for your purchase of SIRUI Professional Products! SIRUI warrants that your purchase is free from defects in materials and workmanship under normal use during the Limited Warranty Period. The Warranty begins on the original date of purchase on your sales receipt and is not transferable. If service is required, a copy of the sales receipt must be included with an explanation of the problem.

Product	Warranty Length
Tripods / Monopods / Accessories	6 years
Humidity Control Cabinet (Cabinet)	3 years
Humidity Control Cabinet (Electronics)	3 years

Model: _____ Date: _____
Store: _____ Serial Number: _____

Warranty coverage can differ from region to region. Please see the contact information below for product registration, information and service for the region the product was purchased in.

SIRUI 6 (six) Year Limited Warranty (3 Year Warranty for Electronic Parts). This warranty shall be limited to repair, adjustment and/or replacement at SIRUI or its authorized distributors option, of defective parts, free of charge (except the cost of transportation to the distributor/service center). Responsibility is limited to the actual cost of the item. Call or Email with questions and send any product to the center in your region. Below is a listing of contact information for Product Registration, Service Inquiries and Questions. SIRUI will not be responsible for expenses or inconveniences, or consequential damages to equipment, or by breach of any expressed or implied warranties.

caused by acts of nature (including, but not limited to fires, floods or earthquakes).
*W Series Waterproof/Dustproof models – Warranty coverage can differ from region to region. Please see contact information below for product registration information and service for the region the product was purchased in.

Warranty Address and Contact Information:
(Please contact the seller or the local distributor where the product was purchased for warranty issues or questions and before any product is sent.)

1. Guangdong SIRUI Optical Co., Ltd.
The Third Industrial District, Wuguishan Town, Zhongshan City, Guangdong, China
Tel: 0086-760-88897373 Fax: 0086-760-88207062
Http://www.sirui.com E-mail: info@sirui-photo.com
Service Hotline: 0086-400 830 2299

2. SIRUI USA, LLC
Add: 29 Commerce Court Verona, NJ 07044
www.sirui.com
Service: Toll Free 866-373-0829 E-mail: info@sirui.com
FOR PRODUCTS PURCHASED IN THE USA PLEASE SEE:
For full details on USA Warranty Terms and Limitations:
www.sirui.com/warranty.html
To register products: www.sirui.com/product-registration.html

3. Focus Nordic AB
For technical support, service or repairs, please contact:
Sweden: info@focusnordic.se www.focusnordic.se
Norway: info@focusnordic.no www.focusnordic.no
Denmark: info@focusnordic.dk www.focusnordic.dk
Finland: info@focusnordic.fi www.focusnordic.fi
Iceland: info@focusnordic.is www.focusnordic.is
Latvia: info@focusnordic.lv www.focusnordic.lv
Estonia: info@focusnordic.ee www.focusnordic.ee
Lithuania: info@focusnordic.lt www.focusnordic.lt
Poland: info@focusnordic.pl www.focusnordic.pl

4. SIRUI Europe GmbH (European Service Center)
Add: Fredericiastr. 2, 14059 Berlin, Germany
Phone: +49 221 94 99 54-50 E-mail: info@sirui.de
(Please contact the seller or your local distributor for warranty issues.)

5. TSE Imaging BV
Add: Argonweg 135, 1362AD Almere, The Netherlands
Telephone: +31 (0)36 8450348 E-mail: service@tse-imaging.nl
(Exclusive Distributor for Netherlands, Belgium, Luxembourg)
www.sirui-photo.nl

6. 대광엔터프라이즈
한국 총판, 기술지원 및 보증서비스 제공.
서울특별시 중구 남대문로 10, 1층
Tel: 02-752-3304 Fax: 02-774-9903
www.sirui.co.kr loweprokr@gmail.com